

O C T A G O N
S Y S T E M S

Embedded PCs For Extreme Environments

**5445/5445E Video / Ethernet Card
User's Manual**

5782(0801)

Copyright

Micro PC™, PC SmartLINK™, CAMBASIC, Octagon Systems Corporation®, the Octagon logo and the Micro PC logo are trademarks of Octagon Systems Corporation.

Disclaimer

Copyright 2001— Octagon Systems Corporation. All rights reserved. However, any part of this document may be reproduced, provided that Octagon Systems Corporation is cited as the source. The contents of this manual and the specifications herein may change without notice.

The information contained in this manual is believed to be correct. However, Octagon assumes no responsibility for any of the circuits described herein, conveys no license under any patent or other right, and makes no representations that the circuits are free from patent infringement. Octagon makes no representation or warranty that such applications will be suitable for the use specified without further testing or modification.

Octagon Systems Corporation general policy does not recommend the use of its products in life support applications where the failure or malfunction of a component may directly threaten life or injury. It is a Condition of Sale that the user of Octagon products in life support applications assumes all the risk of such use and indemnifies Octagon against all damage.



OCTAGON SYSTEMS®

6510 W. 91st Ave.
Westminster, CO 80031

Technical support: 303-426-4521
Telephone: 303-430-1500
FAX: 303-426-8126
Web site: www.octagonsystems.com

IMPORTANT!

Please read the following section before installing your product:

Octagon's products are designed to be high in performance while consuming very little power. In order to maintain this advantage, CMOS circuitry is used.

CMOS chips have specific needs and some special requirements that the user must be aware of. Read the following to help avoid damage to your card from the use of CMOS chips.

○ **Using CMOS circuitry in industrial control**

Industrial computers originally used LSTTL circuits. Because many PC components are used in laptop computers, IC manufacturers are exclusively using CMOS technology. Both TTL and CMOS have failure mechanisms, but they are different. Described below are some of the failures which are common to all manufacturers of CMOS equipment. However, much of the information has been put in the context of the Micro PC.

Octagon has developed a reliable database of customer-induced, field failures. The average MTBF of Micro PC cards exceeds 11 years, yet there are failures. Most failures have been identified as customer-induced, but there is a small percentage that cannot be identified. As expected, virtually all the failures occur when bringing up the first system. On subsequent systems, the failure rate drops dramatically.

- Approximately 20% of the returned cards are problem-free. These cards, typically, have the wrong jumper settings or the customer has problems with the software. This causes frustration for the customer and incurs a testing charge from Octagon.
- Of the remaining 80% of the cards, 90% of these cards fail due to customer misuse and accident. Customers often cannot pinpoint the cause of the misuse.
- Therefore, 72% of the returned cards are damaged through some type of misuse. Of the remaining 8%, Octagon is unable to determine the cause of the failure and repairs these cards at no charge if they are under warranty.

The most common failures on CPU cards are over voltage of the power supply, static discharge, and damage to the serial and parallel ports. On expansion cards, the most common failures are static discharge, over voltage of inputs, over current of outputs, and misuse of the CMOS circuitry with regards to power supply sequencing. In the case of the video cards, the most common failure is to miswire the card to the flat panel display. Miswiring can damage both the card and an expensive display.

- **Multiple component failures:** The chance of a random component failure is very rare since the average MTBF of an Octagon card is greater than 11 years. In a 7-year study, Octagon has never found a single case where multiple IC failures were not caused by misuse or accident. It is very probable that multiple component failures indicate that they were user-induced.
- **Testing “dead” cards:** For a card that is “completely nonfunctional”, there is a simple test to determine accidental over voltage, reverse voltage or other “forced” current situations. Unplug the card from the bus and remove all cables. Using an ordinary digital ohmmeter on the 2,000 ohm scale, measure the resistance between power and ground. Record this number. Reverse the ohmmeter leads and measure the resistance again. If the ratio of the resistances is 2:1 or greater, fault conditions most likely have occurred. A common cause is miswiring the power supply.
- **Improper power causes catastrophic failure:** If a card has had reverse polarity or high voltage applied, replacing a failed component is not an adequate fix. Other components probably have been partially damaged or a failure mechanism has been induced. Therefore, a failure will probably occur in the future. For such cards, Octagon highly recommends that these cards be replaced.
- **Other over-voltage symptoms:** In over-voltage situations, the programmable logic devices, EPROMs and CPU chips, usually fail in this order. The failed device may be hot to the touch. It is usually the case that only one IC will be overheated at a time.
- **Power sequencing:** The major failure of I/O chips is caused by the external application of input voltage while the Micro PC power is off. If you apply 5V to the input of a TTL chip with the power off, nothing will happen. Applying a 5V input to a CMOS card will cause the current to flow through the input and out the 5V-power pin. This current attempts to power up the card. Most inputs are rated at 25 mA maximum. When this is exceeded, the chip may be damaged.

- **Failure on powerup:** Even when there is not enough current to destroy an input described above, the chip may be destroyed when the power to the card is applied. This is due to the fact that the input current biases the IC so that it acts as a forward biased diode on powerup. This type of failure is typical on serial interface chips but can apply any IC on the card.
- **Under rated power supply:** The board may fail to boot due to an under rated power supply. It is important that a quality power supply be used with Octagon Systems cards that has sufficient current capacity, line and load regulation, hold up time, current limiting, and minimum ripple. It is extremely import to select a supply that ramps up in 10ms or less. This assures that all the circuitry on the CPU cards sequences properly and avoids system lockup.
- **Excessive signal lead lengths:** Another source of failure that was identified years ago at Octagon was excessive lead lengths on digital inputs. Long leads act as an antenna to pick up noise. They can also act as unterminated transmission lines. When 5V is switch onto a line, it creates a transient waveform. Octagon has seen submicrosecond pulses of 8V or more. The solution is to place a capacitor, for example 0.1 μ F, across the switch contact. This will also eliminate radio frequency and other high frequency pickup.

Table of Contents

Copyright	2
Disclaimer	2
≡ Using CMOS circuitry in industrial control	3
Table of Contents	6
List of Figures	8
List of Tables	8
Chapter 1: Overview	9
≡ Description	9
Video	9
Ethernet	9
Chapter 2: Installation	10
≡ Hardware installation	10
Using a Micro PC card cage	10
Component Location	11
≡ Connecting the monitor/display	14
Analog Monitor	14
Flat Panel Display	15
Programming the 5445 EEPROM	16
≡ Ethernet	19
IRQs	19
Status LEDs	20
Ethernet Drivers	20
≡ Technical assistance	20
5445/5445E Video / Ethernet technical data	21
≡ Technical specifications	21
Power requirements	21
Environmental specifications	21
Size	21
Interface	21
ROM BIOS	21
Video memory	21
Monitor type	21
Flat panel	21
Mating connectors	22
≡ Maps	22
≡ Interrupts	23

≡ Jumper settings.....	23
≡ Connector pinouts	25
Warranty	28
Limitations on warranty.....	28
Service policy.....	29
Returning a product for repair	29
Returns	30
Governing law	30

List of Figures

Figure 2-1 5445/5445E card component diagram.....	11
Figure 2-2 Edge connector orientation.....	12
Figure 2-3 Populated Micro PC card cage.....	12

List of Tables

Table 2-1 W4 – +3V / +5V flat panel interface voltage select	15
Table 2-2 W1 – BIOS enable/disable jumper	17
Table 2-3 W8 – Ethernet IRQ select jumper	19
Table 2-4 Ethernet LEDs	20
Table A-1 5445 I/O map	22
Table A-2 5445 memory map	22
Table A-3 5445 video interrupts.....	23
Table A-4 5445 Ethernet interrupts.....	23
Table A-5 W1 – BIOS enable/disable jumper	23
Table A-6 W2, W3, W11 and W12 – LCD bias polarity select.....	23
Table A-7 W4 – +3V / +5V flat panel interface voltage select	24
Table A-8 W5 – SHIFTCLK polarity select	24
Table A-9 W6 – 5V or 12V safe select	24
Table A-10 W7 – Video IRQ select jumper	24
Table A-11 W8 – Ethernet IRQ select jumper	24
Table A-12 W10 – LCD bias2 select.....	25
Table A-13 J2 – CRT connector.....	25
Table A-14 J10 – Ethernet connector	26
Table A-15 J1 – Flat panel connector	26

Chapter 1: **Overview**

≡ **Description**

The 5445 SVGA is a small, low power, Micro PC card. The 5445E contains both SVGA video and Ethernet circuitry.

Video

The 5445/5445E Video / Ethernet Card provides CRT and flat panel support. The video controller IC chip provides the following:

- Support for a wide variety of CRT and panel displays for high performance applications.
- Fully SVGA compatible.
- 1 MB of video display memory.
- Supports analog CRT monitors, interlaced and non–interlaced, up to 800 x 600 x 256 colors, or 1024 x 768 x 256 colors.
- Supports monochrome LCD, EL and plasma flat panels up to 1280 x 1024 with 64 gray scales.
- Supports simultaneous CRT & flat panel display. Simultaneous mode is the only operating mode.
- Includes adjustable bias supply for LCD panel.

Note The 5445/5445E card does not support operating systems or drivers that use linear memory or hardware acceleration. This includes Windows 3.xx, Windows 95/98, and Windows NT.

Ethernet

The 5445/5445E Video / Ethernet Card provides a 10Base–T Ethernet port and supports the IEEE 802.3 Ethernet standard. The card uses twisted–pair wiring cable, which is built in a star configuration. The interface terminates at the standard, 8–position, RJ–45 latching phone jack. The Ethernet controller IC chip provides the following:

- 8K x 16 SRAM buffer
- Integrated 10 Base–T transceiver interface
- Two LEDs for link and traffic status integrated into the connector

Chapter 2: *Installation*

The 5445/5445E card requires one slot in a Micro PC card cage. Any slot in the card cage will work. The card plugs directly into the backplane.

≡ Hardware installation

WARNING!

The 5445/5445E card contains static-sensitive CMOS components. The card is most susceptible to damage when it is plugged into another card. The card becomes charged by the user and the static discharges to the system. To avoid damaging your card and its components:

- **Ground yourself before handling the card**
- **Disconnect power before removing or inserting the card.**

WARNING!

Take care to correctly position the 5445/5445E card onto the card slot that it is being installed into.

WARNING!

Octagon assumes no responsibility caused to flat panel displays and/or Micro PC video cards if the display is connected incorrectly.

Using a Micro PC card cage

To install the 5445/5445E card in a Micro PC card cage, you will need the following equipment (or equivalent):

- 5445/5445E Video / Ethernet card
- Micro PC card cage (5xxx Card Cage)
- Power module (510x or 71xx Power Module)
- Octagon CPU card with a Micro PC interface
- VGA compatible monitor with cable

- PC SmartLINK
- Your PC

Component Location

Figure 2-1 shows the 5445/5445E component diagram. Refer to this diagram before connecting the 5445 card.

Figure 2-1 5445/5445E card component diagram

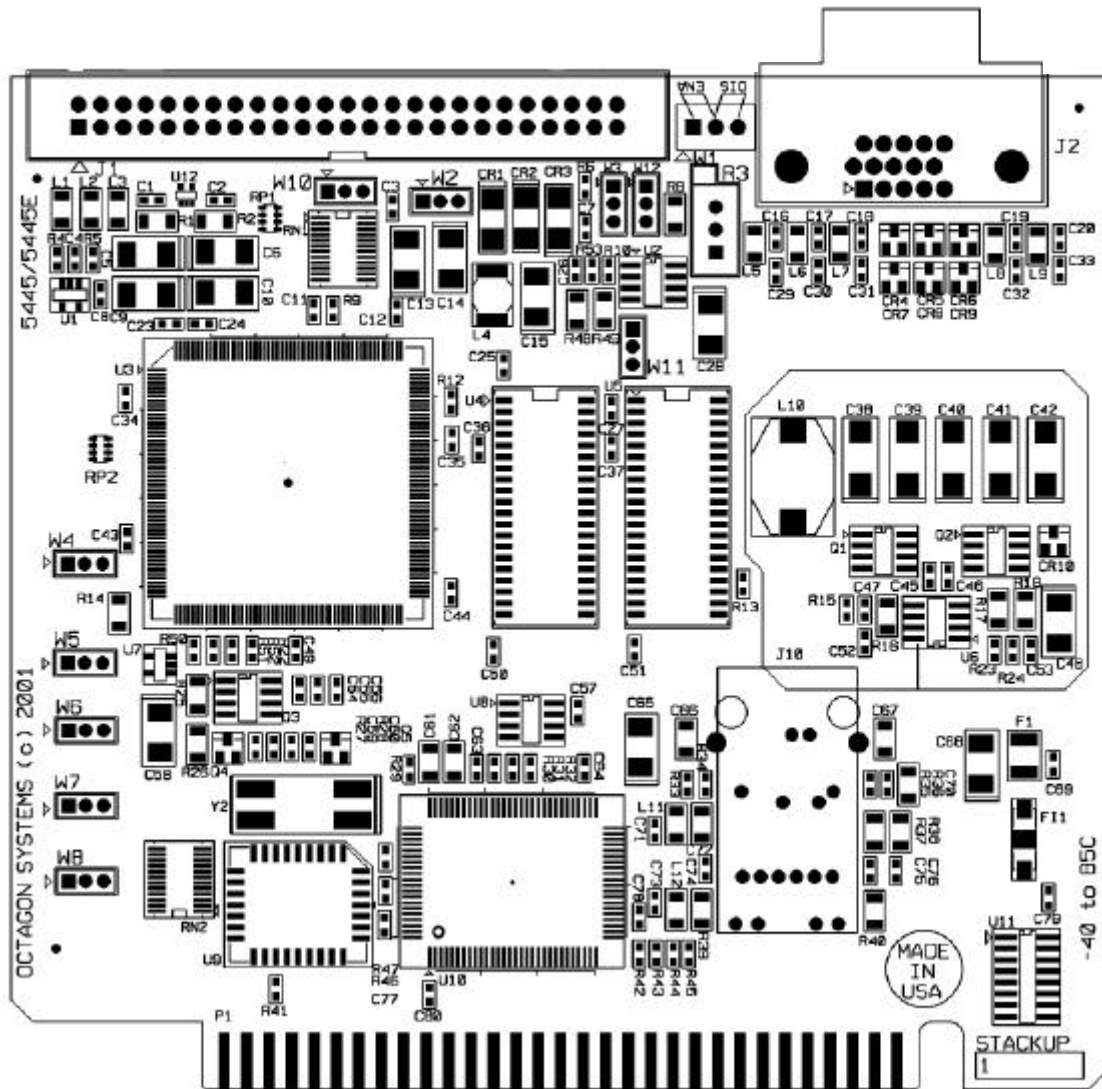

To install the 5445/5445E card:

1. Refer to the component diagram for the location of various connectors before installing the card.

Figure 2-2 Edge connector orientation

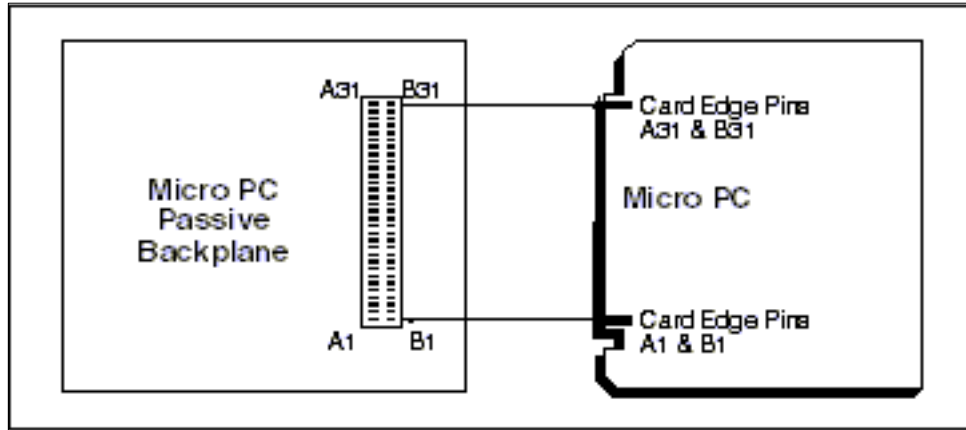

2. Attach the Octagon power module to the card cage following the instructions supplied with the power module.
3. Make sure power to the card cage is OFF.
4. Slide the 5445/5445E card into the card cage. The components on the card should face away from the power supply. See Figure 2-3 for an illustration of the card in a Micro PC card cage.

Figure 2-3 Populated Micro PC card cage

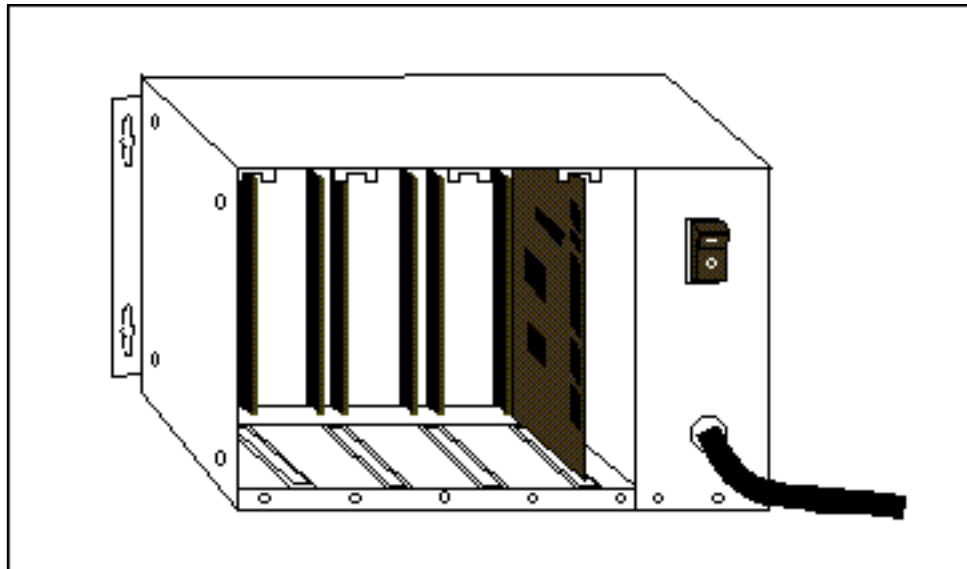

WARNING!

Plugging in the card incorrectly will destroy the card!

5. Power on the system.

≡ **Connecting the monitor/display**

The 5445/5445E supports both a CRT monitor and a flat panel display. The program SM.COM allows you to display from the monitor and some types of flat panels simultaneously. These programs are found on the Octagon Expansion and Accessories CD along with other diagnostic and configuration utilities. The 5445/5445E supports full-time simultaneous operation.

The 5445/5445E is factory configured and programmed with a VGA/SVGA analog monitor driver in the on-card BIOS. If you are using a different monitor or a flat panel display, you must reprogram the video BIOS for the appropriate display (see “Programming the 5445 EEPROM”).

Analog Monitor

1. The CRT connector, J2, interfaces to a standard SVGA monitor.
2. Make sure the BIOS jumper is enabled — W1[1-2].
3. Configure and program your Octagon CPU card for use with a video card and monitor. Refer to your Octagon CPU card user’s manual.
4. Boot your Micro PC system.
5. A BIOS message similar to the following should appear on your video monitor:

```
Octagon xxxx BIOS vers x.xx
```

```
Copyright (c) 2001, Octagon Systems Corp.
```

```
All Rights Reserved.
```

Flat Panel Display

Flat panel displays use either 3V or 5V power. A jumper on the card sets the voltage interface level to match the panel voltage level. Also, some flat panels require a bias voltage. The 5445/5445E bias voltage is adjustable from +19V to +30VDC. The bias voltage must be set prior to connecting the display. A video BIOS for the panel must already be programmed in the EEPROM display (see “Programming the 5445 EEPROM”).

The following jumpers are used to configure flat panel displays:

W2, W3, W11 and W12 – LCD bias polarity select

W4 – +3V or +5V flat panel interface voltage select

W5 – SHIFTCLK polarity select

W6 – 5V or 12V safe select

W10 – LCD bias2 select

Refer to Tables A-4 through A-9 for the jumper settings for all these options.

1. Set the jumper at W4 for your display; either 3V or 5V (see figure 2-1 for the locations).

Table 2-1 W4 – +3V / +5V flat panel interface voltage select

Pins Jumpered	Description
[1-2]	3V flat panel
[2-3] *	5V flat panel

* default

WARNING!

Selecting the incorrect voltage could damage your display.

2. Power on the 5445/5445E and measure Vee between J1, pin 25 (Vee) and pin 2 (gnd). Adjust R3 to the correct bias voltage for your display.

Note Without a flat panel BIOS programmed into the EEPROM and W1[1-2] jumper installed, Vee will not come up.

3. Power off the 5445/5445E and connect the flat panel display to the

J1 connector using a 50-position IDC connector with custom wiring. The Octagon Accessories and Expansion CD contains wiring diagrams for some of the displays. Table A-10 shows the pinout for connector J1.

4. Make sure the BIOS jumper is enabled — W1[1-2].
5. Configure and program your Octagon CPU card for use with a video card and monitor. Refer to your Octagon CPU card user's manual.
6. Power on your Micro PC System.
7. A BIOS message similar to the following should appear on your display:

```
Octagon xxx BIOS vers x.xx  
Copyright (c) 2001, Octagon Systems Corp.  
All Rights Reserved.
```

8. Due to loading of the Vee source, the Vee voltage will probably require additional adjustments at this time in order to obtain proper contrast. With the power on, re-measure Vee at J1 pin 25 and adjust R3 for the correct voltage.

Programming the 5445 EEPROM

The 5445/5445E card is factory configured and programmed to support a standard VGA/SVGA monitor. If you are using the default monitor and have not previously reprogrammed the 5445/5445E, skip this section.

If you are installing the 5445/5445E in a Micro PC system and are using a monitor/display other than VGA/SVGA, read the following instructions. Programming the 5445/5445E requires that you boot the Octagon CPU card from the BIOS drive, and establish a serial communications link between your PC and the Octagon CPU card.

The following instructions assume you are using the 5445/5445E in a Micro PC system.

1. Make sure power to the 5445/5445E is off.
2. Move the W1 jumper to position [2-3]. This disables the BIOS on the 5445/5445E and allows you to use the serial port on your Octagon CPU card.

Table 2-2 W1 – BIOS enable/disable jumper

Pins Jumpered	Description
[1-2]*	Enables the video BIOS
[2-3]	Disables the video BIOS

* default

3. Start PC SmartLINK.

Note Disable any shadowing in the Octagon CPU card SETUP program.

4. Power on the Micro PC system. The Octagon CPU card logon message should display on your PC monitor.
5. Download the file, PGMVIDEO.EXE, and the *.DAT file for your display (e.g., 5445SM.DAT) to your Octagon CPU card. Refer to your Octagon CPU card user's manual for detailed information on downloading files to the Octagon CPU card using the TRANSFER program.

Note Do not power off the 5445/5445E when changing the W1 jumper settings.

6. Move the W1 jumper to position [1-2]. This enables the 5445/5445E BIOS.
7. To program the 5445/5445E for the appropriate monitor/display, type the following:

```
<drive>:PGMVIDEO <drive>:5445SM.DAT
```

The <drive> designator is the read/write drive where you transferred the files from your PC. The *.DAT file should be changed to reflect the type of display you are using.

8. Enter 'Y' when asked if you want to proceed. The program PGMVIDEO then updates the video BIOS on the 5445. The system displays a message similar to the following:

```

Video BIOS programming utility
-----
PGMVIDEO Vers x.x.x Copyright(c) 2001 Octagon Systems Corp.
-----
You must reboot after running this program.

Make sure the jumper labeled EN-DIS is at the EN
position.
```

Do you want to continue? (Y/[N])
Programming...Please wait.....
Verifying...Please wait.....
PGMVIDEO completed.

9. Power off the 5445/5445E and install your monitor/display.

≡ Ethernet

Refer to Figure 2-1 for the location of various connectors.

The 5445E Video / Ethernet card provides a 10Base-T Ethernet port and supports the IEEE 802.3 Ethernet standard. The Ethernet controller IC chip provides the following:

- 8K x 16 SRAM buffer
- Integrated 10 Base-T transceiver interface

The 5445E card uses twisted-pair wiring cable, which is built in a star configuration. The interface terminates at the standard, 8-position, RJ-45 latching phone jack.

Note There cannot be more than one Ethernet port in the Micro PC system.

IRQs

IRQ3, IRQ4, and IRQ5 connect directly to the bus. IRQ10 and IRQ11 can be routed to bus IRQ3 through jumper W8.

Table 2-3 W8 - Ethernet IRQ select jumper

Pins Jumpered	Description
[1-2]	IRQ11 to bus IRQ3
[2-3] *	IRQ10 to bus IRQ3

* default

Note The IRQ selected for the 5445E card must have a matching IRQ on the Octagon CPU card. Different Octagon CPU cards route internal and external IRQs differently. Refer to your CPU manual to determine which IRQ to use.

Status LEDs

Two LEDs provide activity and link status.

Table 2-4 Ethernet LEDs

Color	CR7
Amber	Activity LED: Activated by access to I/O space
Green	Link LED: Activated by network link

Ethernet Drivers

There are two directories for the UM9008/DM9008 Ethernet chip located on the Octagon Expansion and Accessories CD:

1. The Davicom directory is from the www.davicom8.com website.
2. The windrvs directory is from www.windrivers.com which includes DOS and other drivers.

≡ Technical assistance

Carefully recheck your system before calling Technical Support. Run as many tests as possible; the more information you can provide, the easier it will be for the Technical Support staff to help you solve the problem.

Technical Support telephone: 303-426-4521

E-mail Technical Support: Support@octagonsystems.com

Applications Notes (via web): [http://www.octagonsystems.com/ContactUs/ApplicationNotes/application notes.html](http://www.octagonsystems.com/ContactUs/ApplicationNotes/applicationnotes.html)

FAQ (via web): <http://www.octagonsystems.com/ContactUs/FAQ/faq.html>

5445/5445E Video / Ethernet technical data

≡ Technical specifications

Power requirements

5V ±0.25V @ 340 mA typical

Environmental specifications

–40° to 85° C operating

–50° to 90° C, nonoperating

RH 5% to 95%, noncondensing

40g shock, 5g vibration

Size

Micro PC form factor, 4.9 in. X 4.5 in.

Interface

8-bit ISA bus

ROM BIOS

C0000H—C7FFFH

Video memory

Display memory – 1 MB, A0000H—BFFFFH

Linear memory – starting address is dependent upon BIOS; linear memory is not usable

Note The 5445/5445E card does not support operating systems or drivers that use linear memory or hardware acceleration. This includes Windows 3.xx, Windows 95/98, and Windows NT.

Monitor type

Analog VGA monochrome and SVGA color

Flat panel

Supports LCD, EL and plasma flat panels

For further information, refer to the Chips & Technology data sheet for the 65545 High Performance Flat Panel/CRT VGA Controller.

Mating connectors

J2 CRT interface, 15-pin D sub female header:

Receptacle: AMP #746288-1

Strain relief: AMP #499252-5

J1 flat panel interface, 50-pin shrouded header:

Receptacle: AMP #746288-8

Strain relief: AMP #499252-6

≡ Maps

Table A-1 5445 I/O map

Hex range	Function
102H	VGA Global Enable
3B4H – 3DAH	VGA Registers
200H – 2E0H or 300 – 3E0H	Ethernet (user assignable on 20H boundaries)

Table A-2 5445 memory map

Address	Description
A0000H–BFFFFH	1MB of pageable video RAM
C0000H–C7FFFH	Video BIOS
Linear (above 1MB)	Set by BIOS; not available

≡ Interrupts

Table A-3 5445 video interrupts

Interrupt	Description
IRQ2 or IRQ9	Selectable through jumper W7

Table A-4 5445 Ethernet interrupts

Interrupt	Description
IRQ3	Available - direct connect to bus
IRQ4	Available - direct connect to bus
IRQ5	Available - direct connect to bus
IRQ10 or IRQ11	Routed to bus IRQ3 through jumper W8

≡ Jumper settings

Table A-5 W1 – BIOS enable/disable jumper

Pins Jumped	Description
[1-2]*	Enables the video BIOS
[2-3]	Disables the video BIOS

* default

Table A-6 W2, W3, W11 and W12 – LCD bias polarity select

	W2	W3	W11	W12
Positive Bias	[2-3]	[2-3]	[1-2]	[1-2]
Negative Bias *	[1-2]	[2-3]	[1-2]	[1-2]

* default

Table A-7 W4 – +3V / +5V flat panel interface voltage select

Pins Jumpered	Description
[1-2]	3V flat panel
[2-3] *	5V flat panel

* default

Table A-8 W5 – SHIFTCLK polarity select

Pins Jumpered	Description
W5[2-3]	Normal
W5[1-2] *	Inverted

* default

Table A-9 W6 – 5V or 12V safe select

Pins Jumpered	Description
W6[1-2]	12 Vout
W6[2-3] *	5 Vout

* default

Table A-10 W7 – Video IRQ select jumper

Pins Jumpered	Description
[1-2]	IRQ9
[2-3] *	IRQ2

* default

Table A-11 W8 – Ethernet IRQ select jumper

Pins Jumpered	Description
[1-2]	IRQ11 to bus IRQ3
[2-3] *	IRQ10 to bus IRQ3

* default

Table A-12 W10 – LCD bias2 select

Note Some panels do NOT require a bias voltage on J1 pins 22 and 23. This jumper provides or removes the bias voltage to these pins.

Pins Jumpered	Description
W10[1-2]	Provide LCD Bias2 voltage
W10[2-3]*	Remove LCD Bias2 voltage

* default

≡ Connector pinouts

Table A-13 J2 – CRT connector

Signal	Pins	Description
Red	1	output
Green	2	output
Blue	3	output
Reserved	4	nc
Digital Gnd	5	
Red return	6	
Green return	7	
Blue return	8	
+5V safe	9	
Digital Gnd	10	
Reserved	11	nc
Reserved	12	nc
Horizontal Sync	13	output
Vertical Sync	14	output
Reserved	15	nc

Table A-14 J10 – Ethernet connector

Signal	Pins	Description
TX+	1	Transmit +
TX-	2	Transmit -
RX+	3	Receive +
	4	
	5	
RX-	6	Receive -
	7	
	8	

Table A-15 J1 – Flat panel connector

Signal	Pin
DDCLK	1
GND	2
FLM	3
GND	4
LP	5
GND	6
*RASB	7
GND	8
BSHFCLK	9
GND	10
*ENVDD	11
GND	12
P(0)	13
GND	14
P(1)	15
GND	16
P(2)	17
GND	18
P(3)	19
5V SAFE	20
5V SAFE	21
LCD_BIAS2	22
LCD_BIAS2	23

LCD_BIAS	24
LCD_BIAS	25
P(4)	26
GND	27
P(5)	28
GND	29
P(6)	30
GND	31
P(7)	32
GND	33
P(8)	34
GND	35
P(9)	36
GND	37
P(10)	38
GND	39
P(11)	40
GND	41
P(12)	42
GND	43
P(13)	44
SHFCLK	45
P(14)	46
*CASBL	47
P(15)	48
*WEB	49
*OEAB	50
* active low	

Warranty

Octagon Systems Corporation (Octagon), warrants that its standard hardware products will be free from defects in materials and workmanship under normal use and service for the current established warranty period. Octagon's obligation under this warranty shall not arise until Buyer returns the defective product, freight prepaid to Octagon's facility or another specified location. Octagon's only responsibility under this warranty is, at its option, to replace or repair, free of charge, any defective component part of such products.

Limitations on warranty

The warranty set forth above does not extend to and shall not apply to:

1. Products, including software, which have been repaired or altered by other than Octagon personnel, unless Buyer has properly altered or repaired the products in accordance with procedures previously approved in writing by Octagon.
2. Products which have been subject to power supply reversal, misuse, neglect, accident, or improper installation.
3. The design, capability, capacity, or suitability for use of the Software. Software is licensed on an "AS IS" basis without warranty.

The warranty and remedies set forth above are in lieu of all other warranties expressed or implied, oral or written, either in fact or by operation of law, statutory or otherwise, including warranties of merchantability and fitness for a particular purpose, which Octagon specifically disclaims. Octagon neither assumes nor authorizes any other liability in connection with the sale, installation or use of its products. Octagon shall have no liability for incidental or consequential damages of any kind arising out of the sale, delay in delivery, installation, or use of its products.

Service policy

1. If a product should fail during the warranty period, it will be repaired free of charge. For out of warranty repairs, the customer will be invoiced for repair charges at current standard labor and materials rates.
2. Customers that return products for repairs, within the warranty period, and the product is found to be free of defect, may be liable for the minimum current repair charge.

Returning a product for repair

Upon determining that repair services are required, the customer must:

1. Obtain an RMA (Return Material Authorization) number from the Customer Service Department, 303-430-1500.
2. If the request is for an out of warranty repair, a purchase order number or other acceptable information must be supplied by the customer.
3. Include a list of problems encountered along with your name, address, telephone, and RMA number.
4. Carefully package the product in an anti-static bag. (Failure to package in anti-static material will VOID all warranties.) Then package in a safe container for shipping.
5. Write RMA number on the outside of the box.
6. For products under warranty, the customer pays for shipping to Octagon. Octagon pays for shipping back to customer.
7. Other conditions and limitations may apply to international shipments.

Note PRODUCTS RETURNED TO OCTAGON FREIGHT COLLECT OR WITHOUT AN RMA NUMBER CANNOT BE ACCEPTED AND WILL BE RETURNED FREIGHT COLLECT.

Returns

There will be a 15% restocking charge on returned product that is unopened and unused, if Octagon accepts such a return. Returns will not be accepted 30 days after purchase. Opened and/or used products, non-standard products, software and printed materials are not returnable without prior written agreement.

Governing law

This agreement is made in, governed by and shall be construed in accordance with the laws of the State of Colorado.

The information in this manual is provided for reference only. Octagon does not assume any liability arising out of the application or use of the information or products described in this manual. This manual may contain or reference information and products protected by copyrights or patents. No license is conveyed under the rights of Octagon or others.