

Advantech SOM 144 Modules

Introduction

SOM 144 carries the System-On-Module spirit to speed up embedded systems development. It defines the most useful interfaces through a SODIMM and front-end connector on a 2.5" HDD-size PC board. Advantech's SOM 144 Modules provide scalable CPU choices and have condensed many features usually only found on larger control boards. SOM 144 Modules are easy to upgrade, maintain, install, and integrate with customers' applications as well as decrease time to market and cost.

Compact & Powerful

Easy to Upgrade

Fast Time-to-Market

Common Specifications:

I/O expansion: Three master PCI bus (3.3 V PCI)

Enhanced IDE HDD interface: Supports up to two hard disk drives. BIOS auto-detect.

Serial ports: Two serial ports , TTL signal

Universal Serial Bus: Two independent USB interfaces

AC97 Codec interface: AC97 Specification Revision 1.3, 2.0, and 2.1 compliant interface.

Supports ATX power supply

PS/2 Keyboard and PS/2 Mouse interface

FDD/Parallel Port shared bus:

- FDD interface supports up to two floppy disk drives
- Parallel Port supports SPP, ECP and EPP.

BIOS: AWARD 256 KB FLASH BIOS

OS support: Windows® 95/98/NT, Windows® CE 3.0, Linux

Unique Specifications:



SOM-2353 Geode™ GX1 SOM 144/PCI Module

CPU: NS Geode GX1-300 MHz

Chipset: NS CS5530A

RAM memory: 64 MB SDRAM on board

VGA: Supports VGA and VESA, up to 1280 x 1024 @ 8 bpp and 1024 x 768 @ 16 bpp resolution, up to 4 MB share memory

LCD interfaces: 18 bit LCD signal output

Ethernet interface: 10/100 Base-T with RTL8139C controller

SSD: One CompactFlash socket

USB: OpenHCI, Rev. 1.0 specification compliant

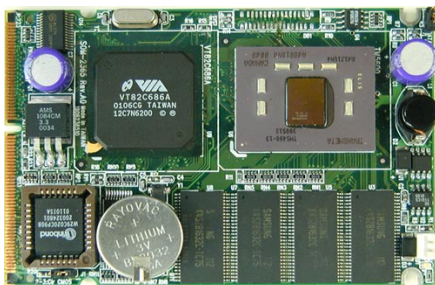

SOM-2365 Transmeta™ TM-5400 SOM 144/PCI Module

CPU: Transmeta TM5400-500 MHz

Chipset: VIA VT82C686A

RAM memory: 64 MB SDRAM on board.

USB: USB 1.1 specification compliant

Development Board:

SOM-DB2300 Development Board for SOM 144 PCI

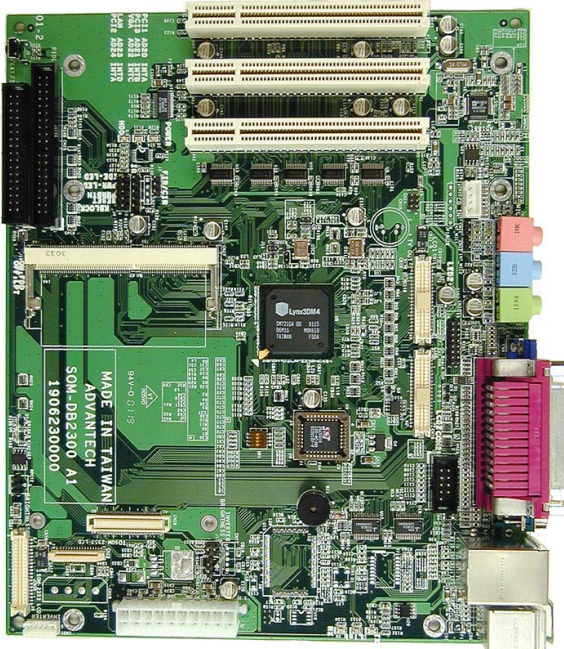

Specifications

- * FlexATX board size with connector allocation on edge
- * Three PCI-bus expansion slots
- * RJ-45 Ethernet connector
- * DB-9 RS-232 serial port connector
- * 10 pin header for RS-232
- * Two USB connectors
- * DB-25 printer port connector
- * One FDD connector
- * 40-pin IDE HDD connector
- * 6-pin PS/2 KB/mouse connector (Keyboard/Mouse split)
- * 5-pin IrDA header
- * VGA chip SMI SM721-4 MB with DB-15 VGA connector
- * Two LCD connectors
- * One TV-out connector
- * One Audio Codec with three Phone Jack connector (Line-out, Line-in, Microphone-in)
- * One CD-in connector

Item No.: **SOM-DB2300**

SOM 144 Mechanical Information:

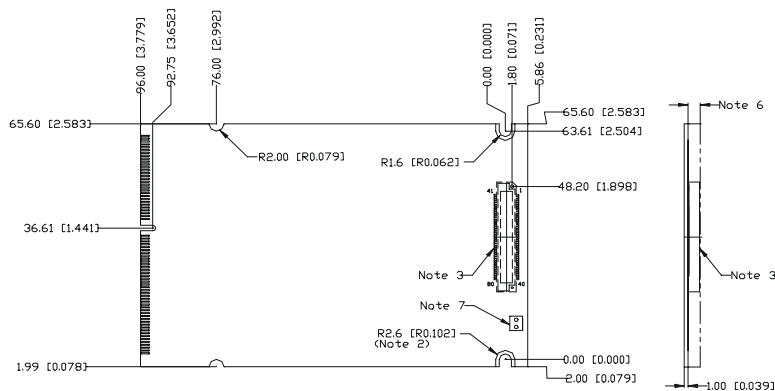

Notes:

1. This view is component side.
2. 1 mm Ground path around the tooling hole(both side).
3. Hirose FXB-80F-3V header, mounted on solder side
4. Keeps outline dim. tolerance within 0.15 mm unless other specified.
5. Follow SODIM specification for layout placement.
6. Component height at solder side is 3 mm Max.
7. Power Conn. for testing.
8. This drawing is only valid for component layout placement.

Dimension unit : mm [Inch]

Installation:

1. Plug the SOM 144 module into the solution board's SODIMM socket.
2. Connect the front-end connector to the solution board
3. Users must screw the SOM 144 Module and the solution board together.

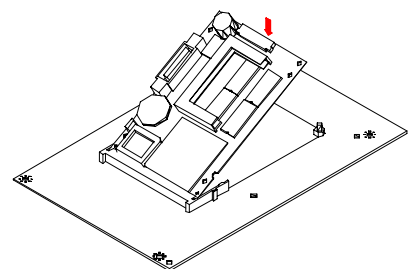
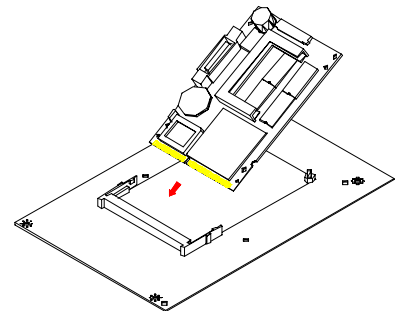

Ordering Information:

SOM-2353-GDA1	GX1-300 SOM 144 PCI Module w /64 MB/VGA/LCD/LAN
SOM-2353P-GDA1	GX1-300 SOM 144 PCI Module w/64 MB/VGA/LCD
SOM-2365L-LDA1	TM-5400-500 SOM 144 PCI Module w/64 MB
SOM-DB2300	Development board for SOM 144 PCI
SOM-DK2353F-C01	Windows CE 3.0 Development Kits for SOM-2353F