

EL

EL640.400-C2, -C3 and -CD3 640 x 400 Pixel Electroluminescent Displays

Product Profile

Operations Manual

The EL640.400-C2, -C3 and -CD3 displays are VGA compatible high-resolution electroluminescent (TFEL) flat panel displays. They replace the bulky CRT in control and instrument product designs. They feature an intergrated DC/DC converter, and their compact dimensions save space that can allow addition of features or reduction in overall size. The two displays are mechanically identical.

The EL640.400-C2, -C3 and -CD3 are timing compatible with Planar EL640.400-CB series displays and signal compatible with VGA Feature Connector supporting the 350 and 400 line standard VGA modes. They may be driven at frame rates up to 80 Hz.

The displays require +5 Vdc and +11...+30 Vdc power input and four to five basic input signals to operate:

1. Video Data or pixel information
2. Video Clock, pixel clock, or dot clock
3. Horizontal Sync
4. Vertical Sync.
5. Blanking in VGA timing modes



EL Technology

A display consists of an electroluminescent glass panel and a mounted circuit board with control electronics.

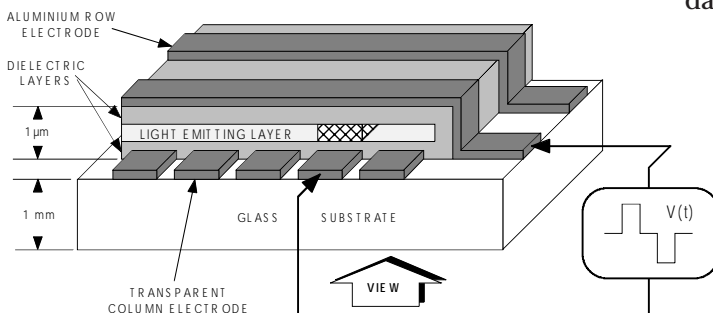

The EL glass panel is a solid-state device with a thin film luminescent layer sandwiched between transparent dielectric layers and a matrix of row and column electrodes. The row electrodes, in back, are aluminum; the column electrodes, in front, are transparent. The entire thin film device is deposited on a single glass substrate. The glass panel is mounted to an electronic circuit assembly board (ECA) with an elastic spacer. The ECA is connected to the EL glass panel with soldered lead frames. The result is a flat, compact, reliable and rugged display device.

The EL640.400-CD3 display includes a light absorbing ICE (Integrated Contrast Enhancement) construction of the display glass. ICE background significantly improves the luminance contrast of the display in bright ambients. The ICE also removes the halo around the lit pixels in dark ambient making the appearance of each pixel extremely crisp and clear.

In the EL640.400-C2, -C3 and -CD3, the 640 column electrodes and 400 row electrodes are arranged in an X-Y formation with the intersecting areas performing as pixels. Voltage is applied to both the correct row electrode and the correct column electrode to cause a lit pixel. Operating voltages required are provided by an integral DC/DC converter.

PLANAR
The Definition of Quality®

Electrical Characteristics

■ Connector Layout

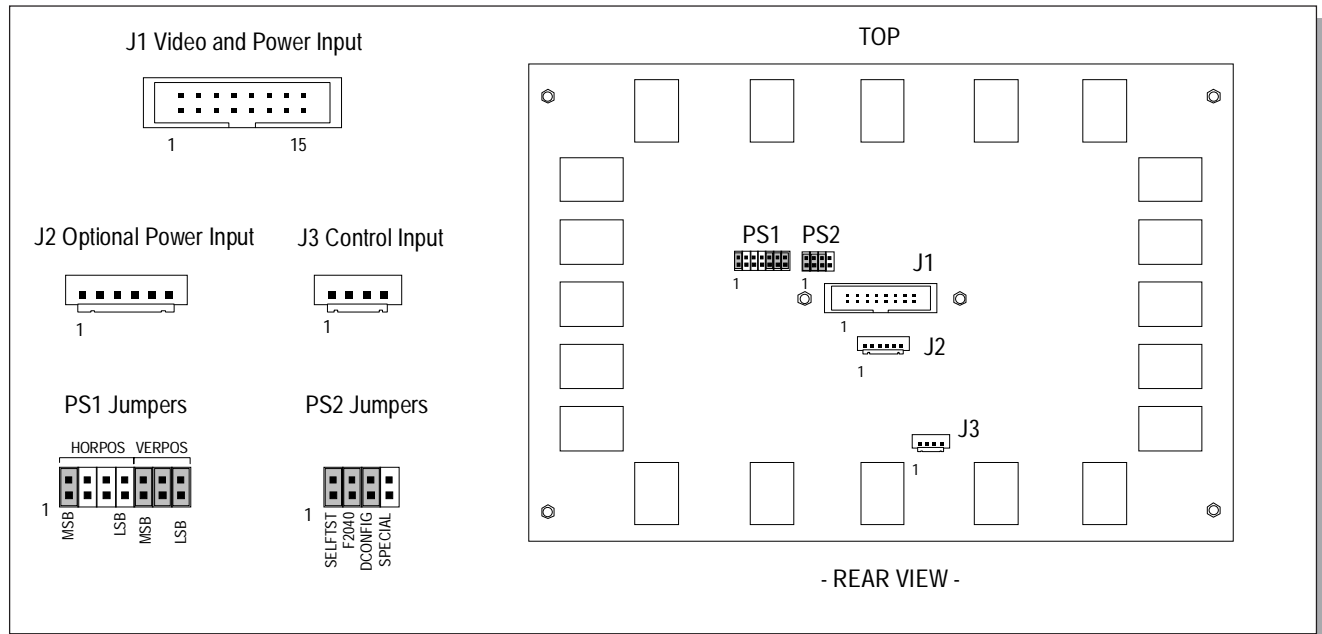

Fig 1. The input connectors and jumpers and their location on EL640.400-C2, -C3 and -CD3 display

Input to the Display

Pins	Signal	Symbol	Description
J1 (Data/power input connector)			
1, 2	Voltage	Vcc2	Supply voltage (+11...+30 V) converted to required internal high voltages (see J2).
3, 4	Voltage	Vcc1	Supply voltage (+5 V) for the logic (see J2).
5	Blanking	_BLANK	Used in VGA and SPECIAL modes. In NORMAL mode should be high or left disconnected.
6, 8, 10			
12, 14, 16	Ground	GND	Signal return.
7	Two-bit data	TVID	Second data input for two bit parallel mode. The TVID input is for odd columns and the VID for even ones.
9	Vertical Sync	VS	The vertical sync signal VS controls the vertical position of the picture.
11	Horizontal Sync	HS	The horizontal sync signal HS controls the internal row counter and in the NORMAL mode the horizontal position of the picture.
13	Video Clock	VCLK	The VCLK signal shifts data present on the VID and TVID lines into the display system. VCLK is active on the rising edge.
15	Video Data	VID	Signal that supplies the pixel information to the system.
J2 (Optional power input connector)			
1	Voltage	Vcc2	Same as J1, Pins 1, 2 (not necessary to connect if power is supplied via J1).
2, 3	Ground	GND	Same as J1 Pins 6, 8, 10, 12, 14, 16 (not necessary to connect if power is supplied via J1).
4	Voltage	Vcc1	Same as J1 Pins 3, 4 (not necessary to connect if power is supplied via J1).
5	Low Power	_LOWPWR	The power consumption of the display is lowered to LOW-POWER-OPERATION values if the _LOWPWR is low, internally pulled high if left disconnected.
6	Enable	ENABLE	The operation of the display unit is disabled if the ENABLE input is low, internally pulled high (enable) if left disconnected.
J3 (Optional control input connector)			
1	Luminance Pot.1	LUMPOT1	The inputs for an external logarithmic 50 kΩ potentiometer to adjust the luminance of the display. Can be left disconnected. The luminance is then at the maximum level.
2	Luminance Pot.2	LUMPOT2	
3	Reserved		Reserved for future use.
4	Reserved		Reserved for future use.

■ Control Basics

The EL panel has 640 transparent column electrodes crossing 400 row electrodes in an X-Y fashion. Light is emitted when an AC voltage is applied at a row-column intersection. The display operation is based on the symmetric, line at a time data addressing scheme which is synchronized by the external VS, HS, and VCLK input signals. The internal control signals and the high voltage pulses for the column and row drivers are generated internally by the control electronics. All control signal inputs are HCT compatible with 100 Ω series resistor.

■ Power Input

The required supply voltages for the display are +5 Vdc (Vcc1) for the logic and +11...+30 Vdc input (Vcc2) for the integrated DC/DC converter. The high voltages needed for driving the display are generated by the DC/DC converter from the Vcc2 input voltage. The input voltages can be connected either through J1 or J2.

■ Connectors

J1	16-pin header mating locking clip	ODU 511.066.003.016 or eqv ODU 517.065.003.016 or eqv ODU 511.065.716.700 or eqv
J2	6-pin header mating protector	Hirose DF1-6P-2.5DSA or eqv Hirose DF1-6S-2.5 R 24 or eqv Hirose DF1-6A 1.33
J4	4-pin header mating protector	Hirose DF1-4P-2.5DSA or eqv Hirose DF1-4S-2.5 R 28 or eqv Hirose DF1-6A 1.33

■ Signal Inputs

For easy interfacing with VGA display controllers the video input signals are VGA Feature Connector compatible. The display automatically determines the mode of operation.

Connector J2 contains two control inputs. LOWPWR input is used to minimize the power consumption of the display and ENABLE input is used to shut off the display when it is not accessed (screen saver function). If the ENABLE or _LOWPWR functions are not in use and the power is connected via J1, the connector J2 can be left disconnected.

Connector J3 contains input for external luminance control it can be left disconnected if its function is not needed.

■ Jumper Description

PS1

The horizontal and vertical positioning of the image can be adjusted with jumpers on pinstrip PS1. VERPOS0...VERPOS2 (MSB) are for vertical positioning and HORPOS0...HORPOS3 (MSB) are for horizontal positioning. Both settings form a binary number where a set jumper is a "0" and open jumper a "1". The adjustment range for VERPOS is 0 to 7 upwards (default 000 for no shift) and HORPOS 7 right (0000) to 8 left (1111) (default 0111 for no shift).

PS2

Position	Name	Function
1	SELFTST	Self test function is selected, if the SELFTEST jumper is OFF. In self test, the input video data at VID and TVID inputs are displayed asynchronously without any other input signals.
2	F2040	200 lines mode. All data is repeated in two consecutive rows. Normally should be installed
3	DCONFIG	The Two-bits-parallel mode is selected if this jumper is OFF (see page 5.)
4	reserved	Reserved, do not insert jumper.

When shipped from the factory, jumpers PS2/1, 2 and 3 are set.

■ Input specifications

Parameter	Symbol	Min.	Typ.	Max.	Absolute max. rating
Logic input HIGH		2 V			Vcc1 +0.5 V
Logic input LOW				0.8 V	-0.5 V
Logic supply voltage	Vcc1	4.75 V	5.0 V	5.25 V	6 V
Logic supply current at 5 V	Icc1	—	—	0.2 A	
Display supply voltage	Vcc2	11 V	—	30 V	33 V
Supply current at 12 V	Icc2		0.8 A	1.6 A	
Supply current at 12 V (LOWPWR)	Icc2		0.5 A	1.0 A	
Power consumption 5 V/12 V			11 W	20 W	
Power consumption 5 V/12 V (LOWPWR)			7 W	13 W	

Operating conditions: Frame rate 70 Hz, ambient temperature 25°C.

Note: Absolute maximum ratings are those values beyond which damage to the device may occur. The minimum and maximum specifications in this Operations Manual should be met, without exception, to ensure the long-term reliability of the display. Planar does not recommend operation of the display outside these specifications.

Display Features

■ Display Operation Modes

EL640.400-C2, -C3 and -CD3 have two input timing modes. VGA Mode supports standard 200, 350 and 400 row VGA modes and Normal Mode is similar to Normal Mode in most Planar displays. Timing mode is determined from combination of the polarities of the VS and HS pulses and the `_BLANK` signal at the rising edge of the VS pulse and the polarities of VS and HS pulses at the rising edge of the `_BLANK` pulse.

In VGA modes, the number of columns is determined by the number of VCLK pulses during a HS pulse. A tolerance of ± 1 pulse is accepted.

VGA Modes: The display data and control input is compatible with feature connector signals from VGA board. The display supports VGA modes 0, 1, 2, 3, 0*, 1*, 2*, 3*, 0+, 1+, 2+, 3+, 4, 5, 6, 7, 7+, D, E, F, 10 and 13. It notifies the polarity of the HS and VS at the rising edge of BLANK and determines the number of rows in the mode. **Note that in VGA modes 0, 1, 0*, 1*, 0+, 1+, 4, 5, D and 13, where the software uses 320 or 360 columns, the size of borders varies from one VGA-controller to another. Therefore the image may not be centered properly using those modes.**

The image is centred automatically, and in text modes with 720 pixels horizontally, every ninth pixel is omitted

■ Supported timing modes

VGA mode	Type	Text format	Char. box	Vsync freq. (Hz)	Pixels (software)	Double scan	Border size	
							h	v
0, 1	text	40 x 25	8 x 8	70	320 x 200	yes	0	7
2, 3	text	80 x 25	8 x 8	70	640 x 200	yes	8	7
0*, 1*	text	40 x 25	8 x 14	70	320 x 350	no	0	6
2*, 3*	text	80 x 25	8 x 14	70	640 x 350	no	8	6
0+, 1+	text	40 x 25	9 x 16	70	360 x 400	no	0	7
2+, 3+	text	80 x 25	9 x 16	70	720 x 400	no	9	7
4, 5	graph	40 x 25	8 x 8	70	320 x 200	yes	0	7
6	graph	80 x 25	8 x 8	70	640 x 200	yes	8	7
7	text	80 x 25	9 x 14	70	720 x 350	no	9	6
7+	text	80 x 25	9 x 16	70	720 x 400	no	9	7
D	graph	40 x 25	8 x 8	70	320 x 200	yes	0	7
E	graph	80 x 25	8 x 8	70	640 x 200	yes	8	7
F	graph	80 x 25	8 x 14	70	640 x 350	no	8	6
10	graph	80 x 25	8 x 14	70	640 x 350	no	8	6
13	graph	40 x 25	8 x 8	70	320 x 200	yes	0	7
Normal mode	graphics			72 max	640 x 400			

NOTES

The top and right borders border values are used for image centering to the display matrix.

In VGA modes 0+, 1+, 2+, 3+, 7 and 7+ the character box is narrowed to 8 pixels by omitting the data of every 9th pixel.

In VGA modes 0, 1, 0*, 0+, 1+, 4, 5, D and 13, where the software uses 320 or 360 columns, the size of borders may vary

for compatibility. The non-displayed pixel is in the space region of the character matrix, and therefore no information is lost. The borders are normally eliminated because of the centering. The upper and lower borders are however displayed in the modes using 350 rows due to extra rows not needed for the picture.

The 480 row VGA modes are not supported. Even if the display does not scan in these modes (11, 12), it continues to operate with no failures when a supported mode is detected.

Normal Mode is pin and timing compatible with MD640.400 Series displays and the Normal mode of EL640.400-CB series displays. In this mode only four input signals are needed: video data (VID), video clock (VCLK), horizontal synchronizing (HS) and vertical synchronizing (VS). `_BLANK` is not in use and should be pulled high or left disconnected.

In Normal mode the last 640 pixels before the fall of the HS are displayed. The topmost row displayed is the first HS HIGH time ending after HS Hold from VS time (T3 in Normal Mode) from the rising edge of VS. If HS is running continuously, the rising edge of the VS can be simultaneous to the previous falling or rising edge of the HS.

See details on the different timing modes as well as setup and hold timing on page 6 and 7.

from one VGA-controller card to another. The potentially needed picture adjustments may be done by programming the registers of the VGA controller chip.

Double Scan is a VGA card feature.

VGA modes 11 and 12 with 480 rows are not supported.

■ Display Enable

The display can be totally shut off for screen save or power reduction by a LOW state in the ENABLE control input. When disabled, the display stops scanning and only the DC/DC converter remains functional. The power consumption only appr. 2 W. In normal operation the ENABLE input should be pulled HIGH or left disconnected (internal pull-up).

■ 200 Rows Mode

200 Input data rows may be displayed using 400 rows by automatically doubling every data row to two consecutive display rows. This function is selected by removing jumper PS2/2 (F2040). The _BLANK input must also be in LOW state. For more information of this mode contact Planar.

■ Two Bit Parallel Data

To reduce the input data frequency in NORMAL mode the Video data can be input two bits per clock cycle. The two data inputs are organized so that the data for the odd columns, numbered from left to the right at the viewers side, is input at the TVID (J1/ pin 7) and the data for the even columns at VID (J1/ pin 15). The two bit parallel mode is selected by removing jumper 3 of the pin strip PS2.

■ Brightness Control

The brightness of the display can be adjusted (appr. between 10 and 100%) by an external 50 k Ω logarithmic potentiometer between the LUMPOT1 and LUMPOT 2 inputs (J3/ pins 1 and 2). The control function is done by feeding a small DC current signal via the external potentiometer from LUMPOT1 (+5 V reference voltage) to LUMPOT2. If the two inputs are left disconnected, the brightness is at its maximum level.

■ Self Test

The operation of the display can be easily checked without any external signals by the self test function.

Remove Jumper 1 in pinstrip PS2.

Connect power to the display.

All pixels of the display will be lit with the exception of the first half of the topmost row.

Installation and Handling

The product should be mounted using the M3 insert nuts on the ECA. Beside the four corner nuts it is recommended to use also the two center nuts in the mounting, if the vibration or shock stress is severe.

Before touching the display, necessary precaution must be taken to prevent application of static charges on the display from the operator or tools.

The display is made of glass material and should be handled with proper care. Do not drop the display or allow hard objects to strike its surface.

NOTE: For trouble-free data transfer a maximum cable length of 300 mm (12 in.) from data transmitter to display input connector is recommended. If longer cables up to 2 m (80 in.) length are needed, a serial resistor of appr. 47 Ω could be placed at each of the five signal line outputs of the transmitter in order to lower signal reflections.

Electrostatic Caution

Planar display use CMOS and power MOS-FET devices. These components are electrostatic sensitive. Unpack, assemble and examine this assembly in a static-controlled area only. When shipping use packing materials designed for protection of electrostatic-sensitive components.

Warning

The product generates potentially dangerous voltages capable of causing personal injury (high voltage pulses up to 195 Vac). Do not touch the display electronics during operation !

Video Input Timing

350 Row VGA Modes (see page 4)

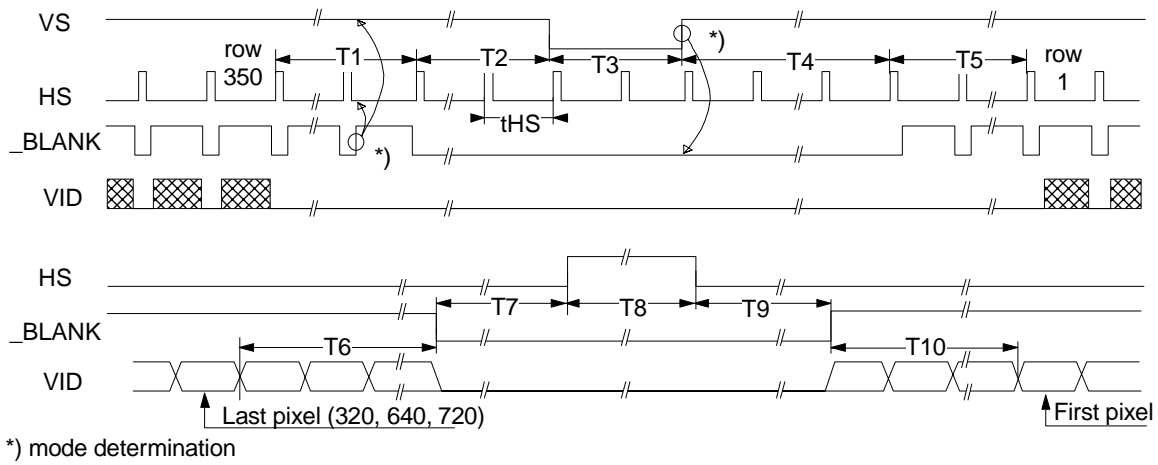

		unit						unit		
T1	Vertical Border	6	tHS	T6	Horizontal Border	0	8	9	tVCLK	
T2	Vertical Front Porch	31	tHS	T7	Horizontal Front Porch	8	8	9	tVCLK	
T3	VS Pulse Width	2	tHS	T8	HS Pulse Width	48	96	108	tVCLK	
T4	Vertical Back Porch	54	tHS	T9	Horizontal Back Porch	24	40	45	tVCLK	
T5	Vertical Border	6	tHS	T10	Horizontal Border	0	8	9	tVCLK	
		449		VCLK pulses / HS		400	800	900		
VS frequency		70	Hz	HS period		31.8	31.8	31.8	μs	

400 Row VGA Modes (see page 4)

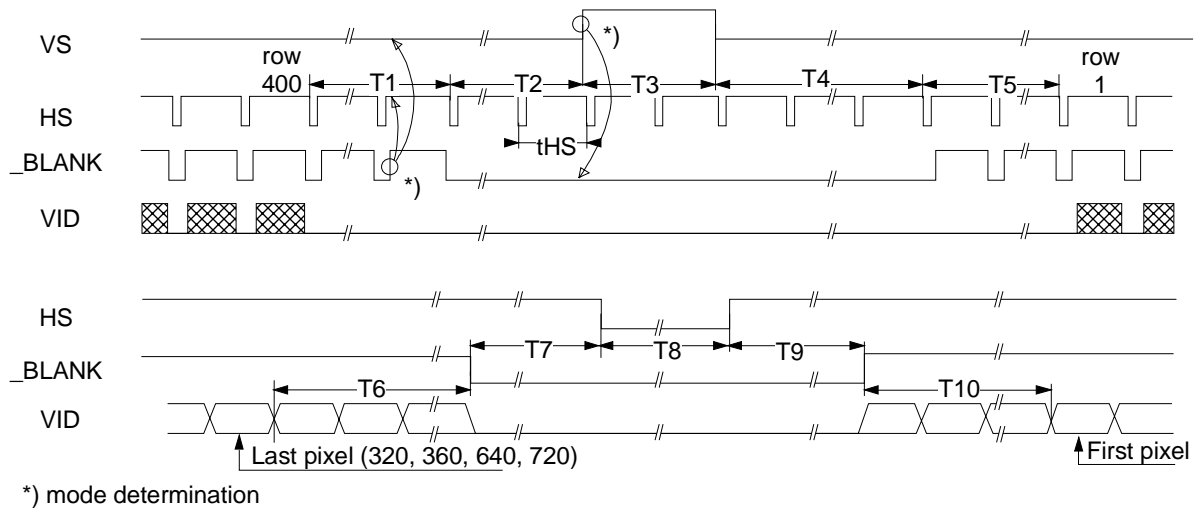

		unit						unit		
T1	Vertical Border	7	tHS	T6	Horizontal Border	0	0	8	9	tVCLK
T2	Vertical Front Porch	5	tHS	T7	Horizontal Front Porch	8	9	8	9	tVCLK
T3	VS Pulse Width	2	tHS	T8	HS Pulse Width	48	54	96	108	tVCLK
T4	Vertical Back Porch	28	tHS	T9	Horizontal Back Porch	24	27	40	45	tVCLK
T5	Vertical Border	7	tHS	T10	Horizontal Border	0	0	8	9	tVCLK
		449		VCLK pulses / HS		400	450	800	900	
VS frequency		70	Hz	HS period		31.8	31.8	31.8	31.8	μs

640 columns x 400 rows (NORMAL mode)

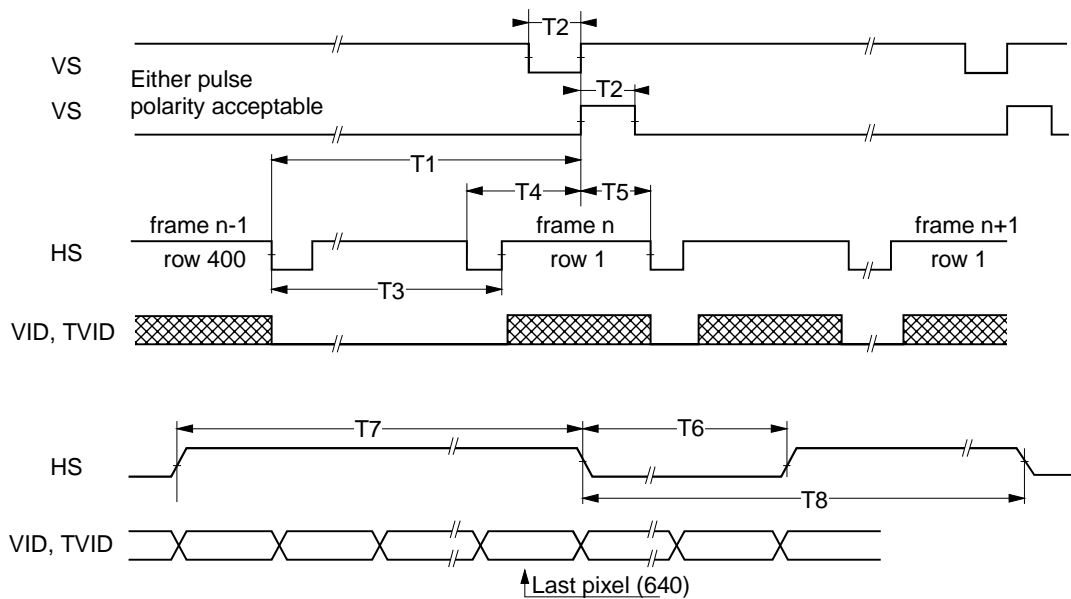

		min	typ	max	unit		min	typ	unit
T1	Vertical Front Porch ¹⁾	60			μs	T4	HS setup to VS	9	tVCLK
T2	VS HIGH/LOW time ²⁾	1			tVCLK	T5	Vertical Back Porch	2	μs
T3	Vertical Blank	40			μs	T6	HS Low Time ⁵⁾	4	tVCLK
	VS frequency		70	80	Hz	T7	HS High Time ⁶⁾	640	640
						T8	HS period	31	μs

- 1) Needed to display the last row and to change the frame.
- 2) Only rising edge is used.
- 3) If vertical positioning is needed, please contact Planar.
- 4) If horizontal positioning is needed, please contact Planar.

- 5) Video Clock VCLK should be kept running.
- 6) The number of VCLK pulses during HS high time should be even.

■ Setup and Hold Timing

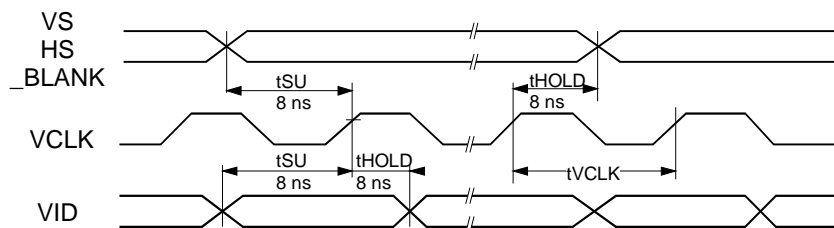

Mode	tVCLK	fVCLK
	ns	MHz
2+, 3+, 7, 7+	35.31	28.322
2, 3, 2*, 3*, 6, E, F, 10	39.71	25.175
0+, 1+	70.62	14.161
0, 1, 0*, 1*, 4, 5, D, 13	79.43	12.588
NORMAL	min 33	max 30

Operational Specifications

■ Environmental

Temperature

Operating	C2: 0...+55°C C3: –25...+65°C
Non-operating	–40...+85°C
Operating Survival (no permanent damage)	C2: –20...+65°C C3: –40...+65°C
Test duration (without condensation):	C2: 24 h at –20°C C3: 24 h at –50°C 24 h at +65°C

Humidity

Relative Humidity	+40°C, 93% RH, Operating (IEC 68-2-3)
Damp Heat	+25...+55°C, 95% RH, Non operating (IEC 68-2-30)

Altitude

Operating	15 000 m (50 000ft.) above sea level
-----------	---

Vibration

20...500 Hz
ASD level 0.05 g²/Hz
Random vibration wide band
IEC 68-2-36, Test Fdb

Shock

Magnitude	100 g
Duration	4 ms (half sine wave)
Number of shocks	18 (3 on each of the 6 surfaces) IEC 68-2-27, test Ea

Reliability

MTBF	greater than 50 000 h at 25°C
------	-------------------------------

EMC

The display will not inhibit the end product from obtaining any of the following specifications:

EN55022 Class B, FCC Part 15J Class B

Safety

The display will not inhibit the end product from obtaining any of the following specifications:

UL544, IEC 950

■ Optical

Determined at 70 Hz frame rate at room temperature.

Display Colour

Wide band amber (Zn:Mn)

Areal Luminance

On luminance (typ.)	C2/C3: 53 cd/m ² (16 fL) CD3: 21 cd/m ² (6.4 fL)
---------------------	---

On luminance (min.)	C2/C3: 45 cd/m ² (13 fL) CD3: 17 cd/m ² (5.0 fL)
---------------------	---

Measured at the center and the four corners of the screen

On luminance variation (time) in 10 000 h	20% max.
--	----------

On luminance variation (temp.) over 0...+55°C range	10% typ. 15% max.
--	----------------------

On luminance non-uniformity	35%
-----------------------------	-----

= (1-min. luminance/max. luminance) x 100.

Maximum difference between any two of five points (center and four corners).

Luminance Contrast Ratio

CD3:	6:1 typical, @ 1 000 lx 1.5:1 typical, @ 10 000 lx
------	---

Illuminance	Classification
10 ... 100 lx	dim
100 ... 1 000 lx	office
1 000 ... 10 000 lx	bright
10 000 ... 100 000 lx	sunlight

Viewing Angle

Greater than 160°

Optional Filter

The luminance contrast of the ICE version of the display EL640.400–CD3 is sufficient for operation without any contrast enhancement. An anti-reflective coating or protecting sheet with anti-reflective treatment is recommended. For best overall performance of EL640.400–C2 and –C3, a neutral gray circular polarizing filter with anti-reflective coating or etch is the usual choice. This filter will make the reflective electrodes of the display darker and will improve the contrast ratio. The anti-reflective coating on the filter should face the user. A Planar filter fits directly in FRA frames. Contact Planar for more details.

See page 12 for available options.

Mechanical Characteristics

■ Display External Dimensions

Fig. 2 shows the mechanical dimensions of the standard EL640.400-C2, -C3 and -CD3 display unit. The display can also be delivered with optional FRA aluminium frames (see Fig. 2). See Ordering Information on page 12.

Height	152.8 mm	6.02 in.
Width	225.8 mm	8.89 in.
Depth	16.5 mm	0.65 in.
Weight	400 g	14 oz.

EL640.400-C2, -C3 and -CD3 displays are mounting compatible with EL640.400-CB series and -CD4/-CD6 displays

■ Display Viewing Area Characteristics

Active area	Height	121.8 mm	4.80 in.
	Width	195.0 mm	7.68 in.
Pixel pitch	Height	0.305 mm	0.012 in.
	Width	0.305 mm	0.012 in.
Pixel size	Height	0.178 mm	0.007 in.
	Width	0.212 mm	0.008 in.
Pixel fill factor	41%		
Pixel matrix	640 horizontal by 400 vertical		

CAUTION: The ambient temperature of the display should not be allowed to exceed the environmental specifications (see page 8). In most applications, an air gap of appr. 5 mm is recommended (see mechanical drawings). Some applications may require, however, a larger air gap or cooling of the display unit in the system. Note that this may slightly increase the total depth of the design.

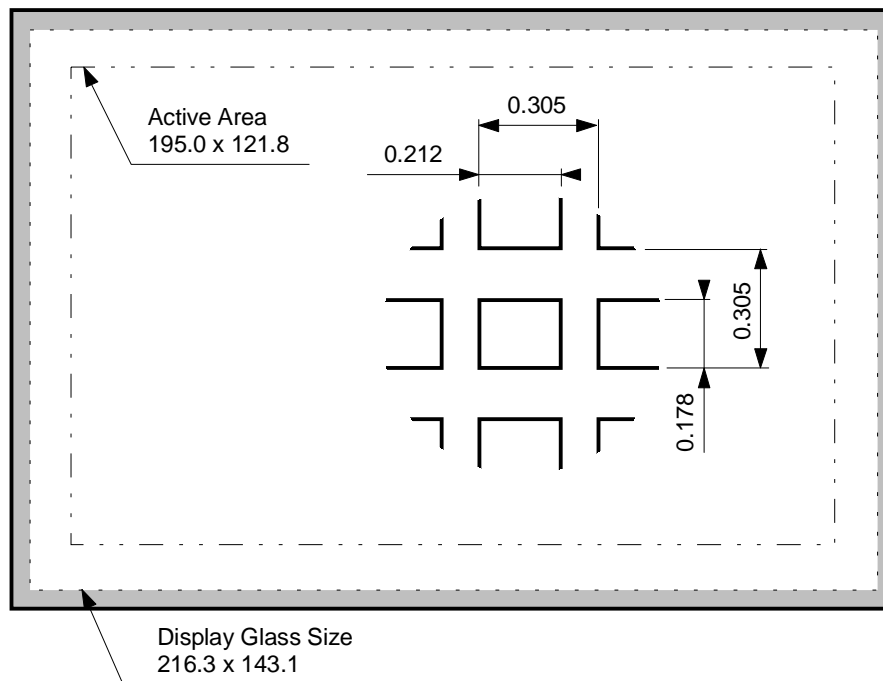
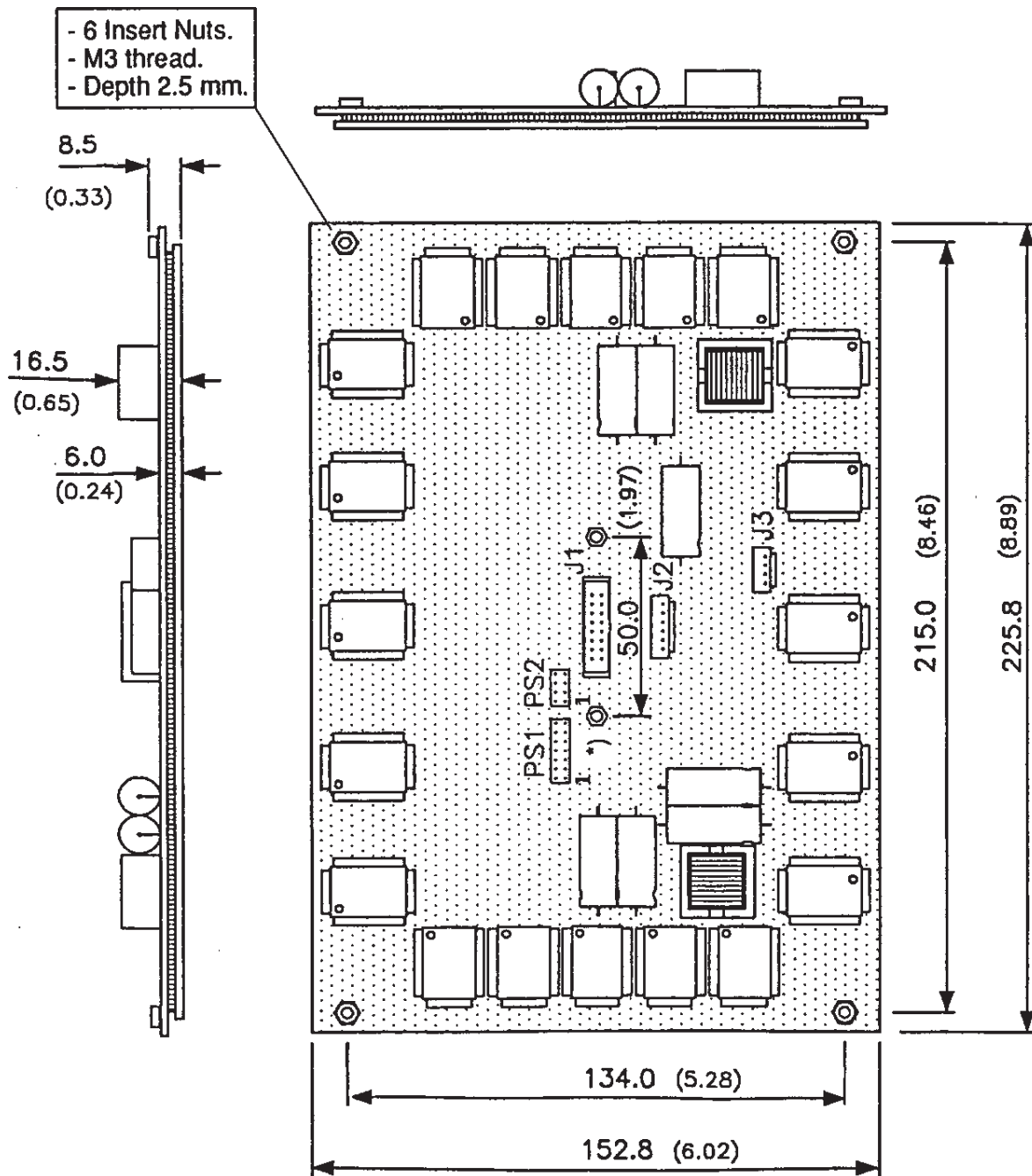

Fig. 2. EL640.400-C2, -C3 and CD3 display, viewing area characteristics



26.04.98
DFC 40639 / 2

*) This Insert Nut is connected to System Ground.
Dimensions in mm (inches).

Fig. 3. EL640.400-C2, -C3 and CD3 displays, back and side views. Dimensions in mm.

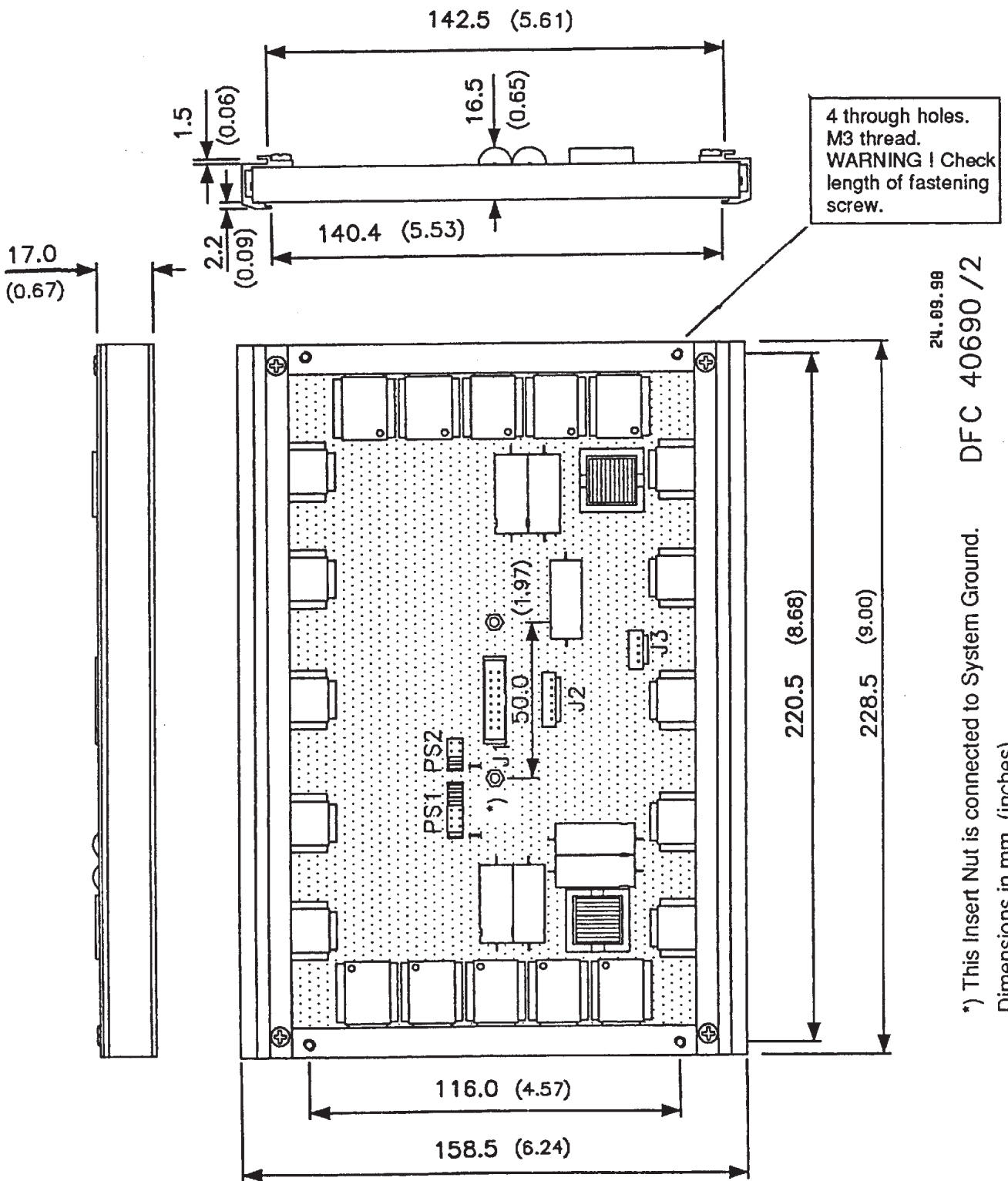

*) This Insert Nut is connected to System Ground.
 Dimensions in mm (inches).

Fig. 4. EL640.400-C2 FRA, -C3 FRA and -CD3 FRA displays, back and side views. Dimensions in mm.

Description of Warranty

This description is not the full warranty, and should not be construed as a substitute for the full warranty. A copy of the full warranty is available upon request.

Planar warrants that the goods it sells will be free of defects in materials and workmanship, and that these goods will substantially conform to the specifications furnished by Planar, and to any drawings or specifications furnished to the Seller by the Buyer if approved by the Seller. This warranty is effective only if Planar receives notice of such defect or nonconformance during the period of warranty, which begins the day of delivery.

The goods Planar sells are warranted for a period of one year unless otherwise agreed to by Planar and the Buyer. The Buyer must return the defective or non-conforming goods, upon request, to Planar not later than 30 days after Planar's receipt of notice of the alleged defect or non-compliance. Buyer shall prepay transportation charges, and Planar shall pay for return of the goods to the Buyer. No goods are to be returned to Planar without prior written permission.

The warranty does not apply in cases of improper or inadequate maintenance by the Buyer, unauthorized modification of the goods, operation of the goods outside their environmental specifications, neglect or abuse of the goods, or modification or integration with other goods not covered by a Planar warranty when such modification or integration increases the likelihood of damage of the goods.

Represented by:

© Planar Systems, Inc. 1/1998

Planar and "The Definition of Quality" are registered trademarks of Planar Systems, Inc.. ICE™ is a trademark of Planar Systems, Inc.

North & South America OEM Sales:

Planar America, Inc.
1400 NW Compton Drive
Beaverton, OR USA 97006-1992
Tel: (503) 690-6967
Fax: (503) 690-1493
sales@planar.com

Europe & Asia-Pacific OEM Sales:

Planar International Ltd.
P.O. Box 46
Olarinluoma 9
FIN-02201 Espoo, Finland
Tel: +358-9-42001
Fax: +358-9-422143
intl@planar.com

Federal & End-User System Sales:

Planar Advance, Inc.
P.O. Box 4001
13950 Karl Braun Drive
Beaverton, OR USA 97076-4001
Tel: (503) 614-4111
Fax: (503) 614-4101
display_solutions@planar.com

Easy to Use

There are many options available which make Planar flat panel displays easy to use, easy to interface, and easy to package. Call Planar for complete information.

Support and Service

Planar is a US company based in Beaverton, Oregon and Espoo, Finland with a world-wide sales distribution network. Full application engineering support and service are available to make the integration of Planar displays as simple and quick as possible for our customers.

RMA Procedure: For a Returned Material Authorization number, please contact Planar International Ltd., or Planar Systems, Inc., with the model number(s) and original purchase order number(s). When returning goods for repair, please include a brief description of the problem, and mark the outside of the shipping container with the RMA number.

Ordering Information

EL640.400-C2	0...+55°C oper. temp. range
EL640.400-C3	-25...+65°C oper. temp. range
EL640.400-CD3	ICE display with -25...+65°C oper. temp. range

With aluminium mounting frame

EL640.400-C2 FRA

EL640.400-C3 FRA

EL640.400-CD3 FRA

With optically bonded anti-glare film

EL640.400-CD3 AG

Circular polarizing contrast enhancement filters

ELF644-GNNN, Glass CP filter for -C2 and -C3

ELF644FRA-GNNN, Glass CP filter for
-C2 FRA and -C3 FRA

ELF640FRA-ANNN, Acrylic CP filter for
-C2 FRA and -C3 FRA

Clear impact resistant sheet

ELF640FRA-ACNA, Acrylic sheet for -CD3 FRA

Design and Specifications subject to change without notice.

PLANAR[®]
The Definition of Quality