

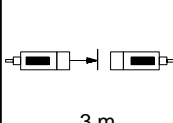

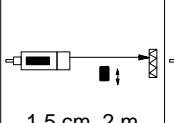
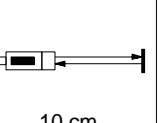

Sensing			Supply Voltage	Output	
			10 to 30 VDC 24 to 240 VAC, 50/60 Hz		
3 m	1.5 cm, 2 m	10 cm		5 to 200 mA, 250 VAC	100 mA, 24 VDC

Photoelectric Sensor

E3F2

Threaded Cylindrical M18 Size Sensors with Built-in Amplifier

- Chemical resistant, ABS resin case
- Compact and space-saving
- Long detection distance (30 cm) with sensitivity adjustor for diffuse type (DC switching type)
- DC switching types with connectors for easy maintenance
- Wide operating voltage range (10 to 30 VDC, or 24 to 240 VAC)
- Short-circuit and reverse connection protection (DC switching type)
- UL, CSA, and CE approved



Ordering Information

■ SENSORS

DC Switching Models

Power Supply	Operating Modes	Connection Method	Control Output	Detection Method	Detection Distance	Part Number	
10 to 30 VDC	Light-ON/ Dark-ON (selectable)	Pre-wired cable	Transistor output, NPN open collector	Through-beam	3 m (9.84 ft) 4 m typ. (13.12 ft)	E3F2-3C4	
				Retroreflective	2 m (6.56 ft) 2.5 m typ. (8.20 ft)	With E39-R1 reflector	E3F2-R2C4
						Without reflector	E3F2-R2C4-E
				Diffuse reflective	10 cm (3.94 in)	Wide beam	E3F2-DS10C4-N
					30 cm (11.81 in) 40 cm typ. (15.75 in)		E3F2-DS30C4
				Transistor output, PNP open collector	Through-beam	3 m (9.84 ft) 4 m typ. (13.12 ft)	E3F2-3B4
			Retroreflective		2 m (6.56 ft) 2.5 m typ. (8.20 ft)	With E39-R1 reflector	E3F2-R2B4
					Without reflector	E3F2-R2B4-E	

Power Supply	Operating Modes	Connection Method	Control Output	Detection Method	Detection Distance	Part Number				
10 to 30 VDC	Light-ON/ Dark-ON (selectable)	Pre-wired cable	Transistor output, PNP open collector	Diffuse reflective	10 cm (3.94 in) Wide beam	E3F2-DS10B4-N				
					30 cm (11.81 in) 40 cm typ. (15.75 in)	E3F2-DS30B4				
					3 m (9.89 ft) 4 m typ. (13.12 ft)	E3F2-3C4-P1				
		Connector	Transistor output, NPN open collector	Through-beam	Through-beam	Through-beam	3 m (9.89 ft) 4 m typ. (13.12 ft)	E3F2-3B4-P1		
							Retroreflective	2 m (6.56 ft) 2.5 m typ. (8.20 ft)	With E39-R1 reflector	E3F2-R2C4-P1
									Without reflector	E3F2-R2C4-P1E
				Diffuse reflective	10 cm (3.94 in) 30 cm (11.81 in) 40 cm typ. (15.75 in)			E3F2-DS10C4-P1		
								E3F2-DS30C4-P1		
		Transistor output, PNP open collector	Through-beam	Through-beam	Through-beam	3 m (9.89 ft) 4 m typ. (13.12 ft)	E3F2-3B4-P1			
							Retroreflective	2 m (6.56 ft) 2.5 m typ. (8.20 ft)	With E39-R1 reflector	E3F2-R2B4-P1
									Without reflector	E3F2-R2B4-P1E
Diffuse reflective	10 cm (3.94 in) 30 cm (11.81 in) 40 cm typ. (15.75 in)			E3F2-DS10B4-P1						
				E3F2-DS30B4-P1						

AC Switching Models

Power Supply	Operating Modes	Connection Method	Control Output	Detection Method	Detection Distance	Part Number
24 to 240 VAC, 50/60 Hz	Light-ON (Fixed)	Pre-wired cable	AC solid state (SCR)	Through-beam	3 m (9.89 ft) 4 m typ. (13.12 ft)	E3F2-3Z1
				Retroreflective	2 m (6.56 ft) 2.5 m typ. (8.20 ft)	E3F2-R2Z1
				Diffuse reflective	10 cm (3.94 in)	E3F2-DS10Z1
	Dark-ON (Fixed)			Through-beam	3 m (9.89 ft) 4 m typ. (13.12 ft)	E3F2-3Z2
				Retroreflective	2 m (6.56 ft) 2.5 m typ. (8.20 ft)	E3F2-R2Z2
				Diffuse reflective	10 cm (3.94 in)	E3F2-DS10Z2

ACCESSORIES

Description	Part Number
Sensor mounting bracket	Y92E-B18
Lens protector kit (glass plate, two gaskets and metal retainer)	E39-F31
Small corner cube reflector (38 H x 20 W x 11 D mm)	E39-R3
Adhesive backed reflector (10 H x 35 W x 0.7 D mm)	E39-RSA
Adhesive backed reflector (35 H x 40 W x 0.7 D mm)	E39-RSB
Mounting bracket for E39-R1 reflector	E39-L7
Right angle adapter for through-beam and retroreflective E3F2 sensors	E39-RU1

CONNECTOR CORD SETS

Connector Type	Cable Size	Length	Straight Connector	Right Angle Connector
4-wire DC Micro Change® connector	22 AWG	2 m (6.56 ft)	Y96E-44SD2	Y96E-44RD2
		5 m (16.40 ft)	Y96E-44SD5	Y96E-44RD5
		10 m (32.8 ft)	Y96E-44SD10	Y96E-44RD10

■ REPLACEMENT PARTS

Description	Part Number
Reflector for E3F2-R2□4 retroreflective sensors	E39-R1
Two plastic M18 mounting nuts	E3F-PHWS

Specifications

DC Switching Models

Part number	E3F2-3B4 E3F2-3C4	E3F2-R2B4(-E) E3F2-R2C4(-E)	E3F2-DS10B4-N E3F2-DS10C4-N	E3F2-DS30B4 E3F2-DS30C4
Method of detection	Through-beam	Retroreflective	Diffuse reflective	
Supply voltage	10 to 30 VDC (10% maximum permissible ripple peak-to-peak)			
Current consumption	Emitter: 25 mA max. Receiver: 20 mA max.	25 mA max.		
Sensing distance	3 m (9.84 ft) 2.5 m (8.2 ft) with E39-RU1	0.1 to 2 m with E39-R1 (3.94 in to 6.56 ft) 5 to 100 cm with E39-R3 (1.97 to 39.37 in) 20 to 80 cm with E39-RSB (7.87 to 31.50 in) 20 to 50 cm with E39-RSA (7.87 to 19.69 in)	10 cm (3.94 in) with 5x5 cm (2x2 in) 90% reflectance white mat paper	30 cm (11.81 in) with 10x10 cm (4x4 in) 90% reflectance white mat paper
Light source	Pulse modulated infrared LED			
Detectable object type	Opaque materials, 11 mm (0.43 in) minimum dimension	Opaque materials, 56 mm (2.21 in) minimum dimension	Opaque and transparent materials	
Differential travel	—		20% max.	
Operation mode	Light-ON/Dark-ON, wire selectable			
Sensitivity	Fixed			Adjustable, 3/4-turn
Mutual interference protection	Not provided			
Control output	DC solid state	Type	NPN-SPST open collector (E3F2-□□C4-□) PNP-SPST open collector (E3F2-□□B4-□)	
		Max. load	100 mA max., 10 to 30 VDC	
		Voltage drop max. on-state	2 VDC max. at 100 mA 1 VDC max. at 20 mA	
Response time	ON	2.5 ms max.		
	OFF	2.5 ms max.		
Power reset time	50 ms max.			
Circuit protection	Output short-circuit	Provided		
	DC power supply reverse polarity	Provided		
Indicators	Emitter: Power ON (red LED) Receiver: Light incident (red LED)	Light incident (red LED)		
Materials	Lens	Plastic		
	Case	Plastic		
	Cable sheath	PVC		
Mounting	M18 threaded body, two plastic nuts included			
Connections	Prewired	Emitter: 2-conductor cable, 2 m (6.56 ft) length Receiver: 4-conductor cable, 2 m (6.56 ft) length	4-conductor cable, 2 m (6.56 ft) length	
Weight	Prewired	Emitter: 110 g (4 oz.) Receiver: 110 g (4 oz.)	110 g (4 oz.)	

Part number		E3F2-3B4 E3F2-3C4	E3F2-R2B4(-E) E3F2-R2C4(-E)	E3F2-DS10B4 E3F2-DS10C4	E3F2-DS30B4 E3F2-DS30C4
Enclosure	UL	—			
	NEMA	1, 2, 4X, 12			1, 2, 4X
	IEC 144	IP67			IP66
Approvals	UL	—			
	CSA	—			
	CE	EN50082-2:1995/EN61000-4-2:1995/IEC801-2:1991/ENV50140:1993/ENV50141:1993/ EN61000-4-4:1995/IEC801-4:1988/EN50081-2:1994/EN55011:1991			
Ambient temperature	Operating	-25° to 55°C (-13° to 131°F)			
	Storage	-30° to 70°C (-22° to 159°F)			

AC Switching Models

Part number		E3F2-3Z1 E3F2-3Z2	E3F2-R2Z1 E3F2-R2Z2	E3F2-DS10Z1 E3F2-DS10Z2
Method of detection		Through-beam	Retroreflective	Diffuse reflective
Supply voltage		24 to 240 VAC ±10%, 50/60 Hz		
Current consumption		10 mA max. (emitter and receiver)	5 mA max.	
Sensing distance		3 m (9.84 ft) 2.5 m (8.2 ft) with E39-RU1	0.1 to 2 m with E39-R1 (3.94 in to 6.56 ft) 5 to 100 cm with E39-R3 (1.97 to 39.37 in) 20 to 80 cm with E39-RSB (7.87 to 31.50 in) 20 to 50 cm with E39-RSA (7.87 to 19.69 in)	10 cm (3.94 in) with 5x5 cm (2x2 in) 90% reflectance white mat paper
Light source		Pulse modulated infrared LED		
Detectable object type		Opaque materials, 11 mm (0.43 in) minimum dimension	Opaque materials, 56 mm (2.21 in) minimum dimension	Opaque and transparent materials
Differential travel		—		
Operation mode		Light-ON E3F2-□□Z1 Dark-ON E3F2-□□Z2		
Sensitivity		Fixed		
Mutual interference protection		Not provided		
Control output	AC solid state	Type	SCR	
		Max. load	200 mA max., 24–240 VAC	
		Residual voltage	5 V max. at 200 mA	
Response time	ON	30 ms max.		
	OFF	30 ms max.		
Power reset time		100 ms max.		
Circuit protection	Output short-circuit	Provided		
	DC power supply reverse polarity	Provided		
Indicators		Emitter: Power ON (red LED) Receiver: Light incident (red LED)	Light incident (red LED)	
Materials	Lens	Plastic		
	Case	Plastic		
	Cable sheath	PVC		
Mounting		M18 threaded body, two plastic nuts included		
Connections	Prewired	Emitter: 2-conductor cable, 2 m (6.56 ft) length Receiver: 3-conductor cable, 2 m (6.56 ft) length	3-conductor cable, 2 m (6.56 ft) length	
Weight	Prewired	Emitter: 110 g (4 oz.) Receiver: 110 g (4 oz.)	110 g (4 oz.)	

Part number		E3F2-3Z1 E3F2-3Z2	E3F2-R2Z1 E3F2-R2Z2	E3F2-DS10Z1 E3F2-DS10Z2
Enclosure	UL	—		
	NEMA	1, 2, 4X, 12		
	IEC 144	IP66		
Approvals	UL	Recognized, File No. E41515		
	CSA	Certified, File No. LR45951		
Ambient temperature	Operating	-25° to 55°C (-13° to 131°F)		
	Storage	-30° to 70°C (-22° to 159°F)		

Engineering Data

■ OPERATING RANGE (TYPICAL)

E3F2-3□□-□□ (Through-beam)

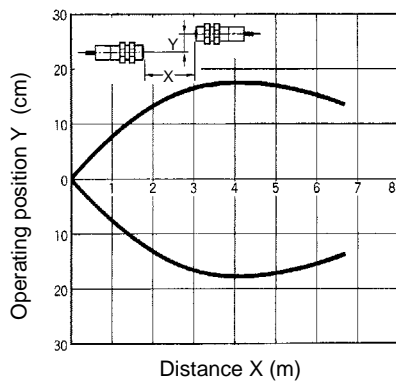

E3F2-R2□□-□□ (Retroreflective)

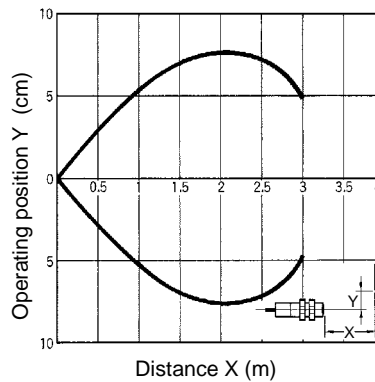

E3F2-3 and E39-RU1

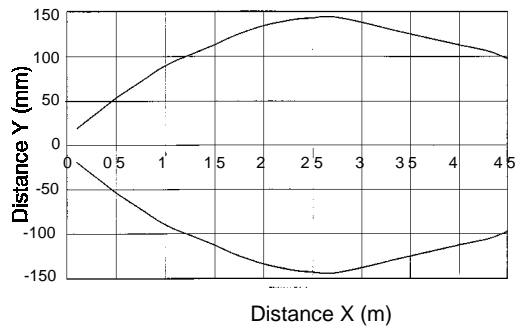

E3F2-R2 and E39-RU1

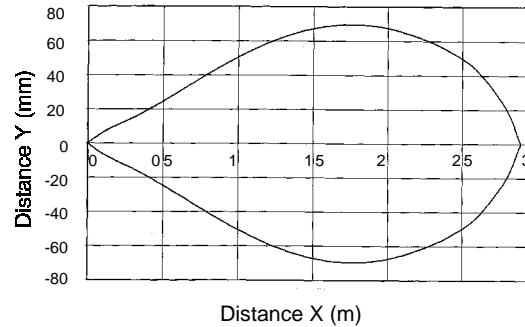

E3F2-DS10□□-N
E3F2-DS10□4-P1

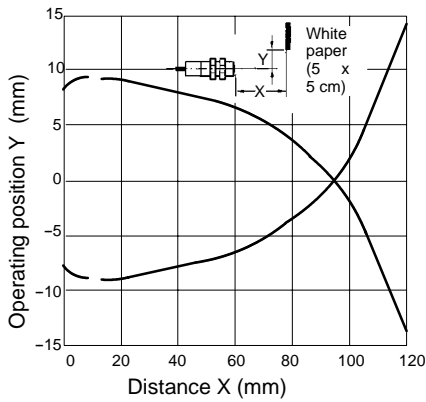

E3F2-DS30□□-□□

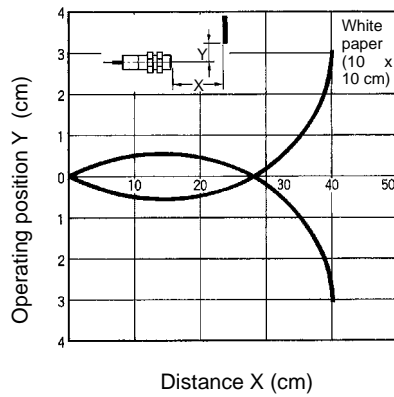

■ EXCESS GAIN VS. SET DISTANCE (TYPICAL)

E3F2-3□□-□□

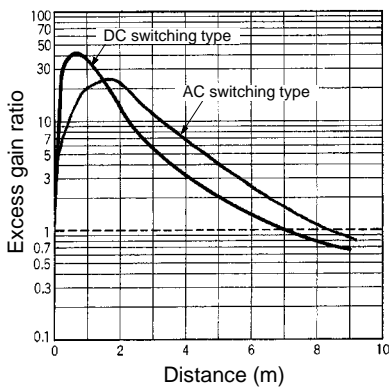

E3F2-R2□□-□□

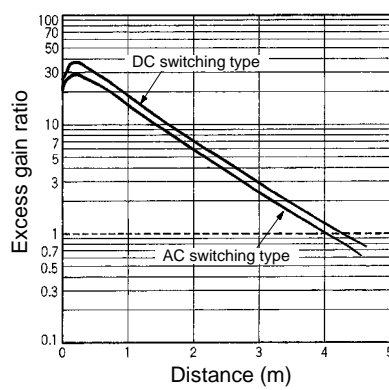

E3F2-3 and E39-RU1

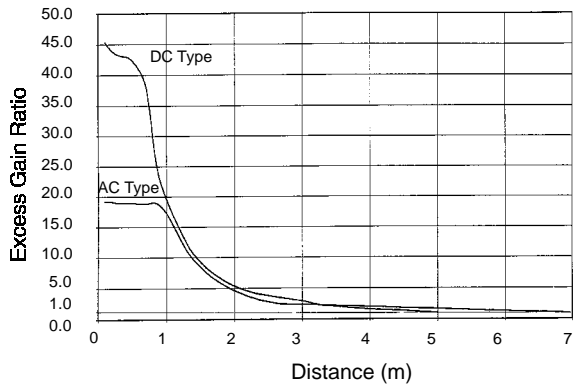

E3F2-R2 and E39-RU1

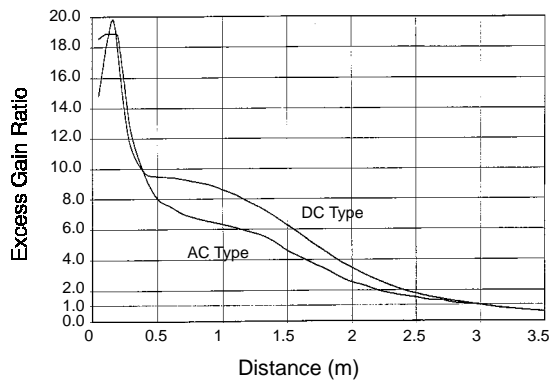

■ EXCESS GAIN VS. SET DISTANCE

E3F2-DS10Z□-N

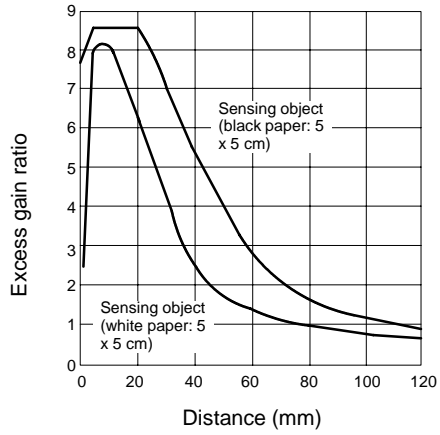

E3F2-DS10□4-N
E3F2-DS10□4-P1

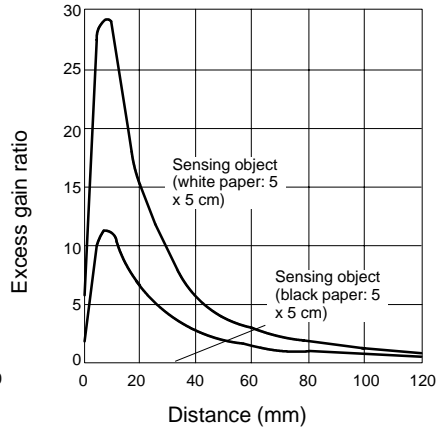

E3F2-DS10Z□

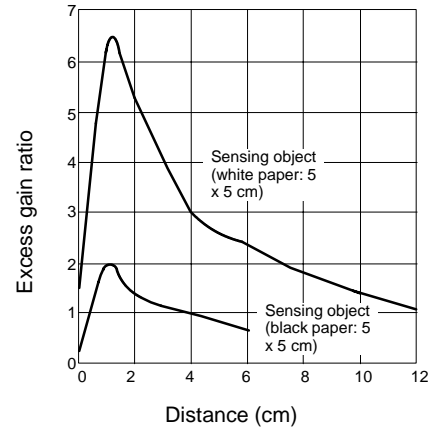

E3F2-DS30□4
E3F2-DS30□4-P1

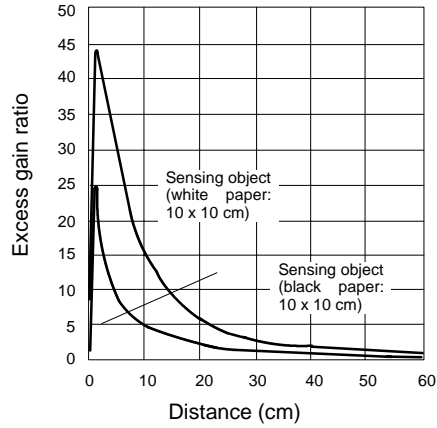

Operation

OUTPUT CIRCUITS

Configuration	Part Number	Connection Method	Output Transistor	Output Circuit
NPN pre-wired cable	E3F2-3C4 E3F2-R2C4 E3F2-DS10C4-N E3F2-DS30C4	Connect the pink and brown cords or open the pink cord.	ON when light is incident. (Light-ON)	
		Connect the pink and blue cords.	ON when light is interrupted. (Dark-ON)	
PNP pre-wired cable	E3F2-3B4 E3F2-R2B4 E3F2-DS10B4-N E3F2-DS30B4	Connect the pink and brown cords or open the pink cord.	ON when light is incident. (Light-ON)	
		Connect the pink and blue cords.	ON when light is interrupted. (Dark-ON)	
NPN connector	E3F2-3C4-P1 E3F2-R2C4-P1 E3F2-DS10C4-P1 E3F2-DS30C4-P1	Connect the pink and brown cords or open the pink cord.	ON when light is incident. (Light-ON)	
		Connect the pink and blue cords.	ON when light is interrupted. (Dark-ON)	

Configuration	Part Number	Connection Method	Output Transistor	Output Circuit
PNP connector	E3F2-3B4-P1 E3F2-R2B4-P1 E3F2-DS10B4-P1 E3F2-DS30B4-P1	Connect the pink and brown cords or open the pink cord.	ON when light is incident. (Light-ON)	
		Connect the pink and blue cords.	ON when light is interrupted. (Dark-ON)	
AC switching	E3F2-3Z1 E3F2-R2Z1 E3F2-DS10Z1-N	--- (Fixed)	ON when light is incident. (Light-ON)	
	E3F2-3Z2 E3F2-R2Z2 E3F2-DS10Z2-N		ON when light is interrupted. (Dark-ON)	

Note: Terminal numbers for connector type.

■ TIMING CHART

Light-ON Mode

With Pink (2) connected to Brown (1)

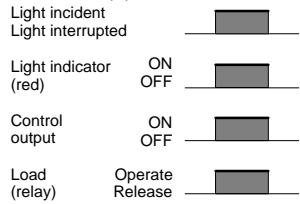

Dark-ON Mode

With Pink (2) connected to Blue (3)

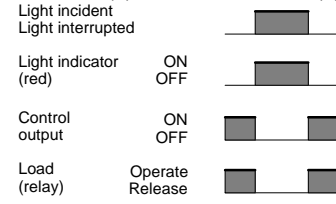

Dimensions

Unit: mm (inch)

E3F2-3C4, E3F2-3B4 (Light Source and Receiver)

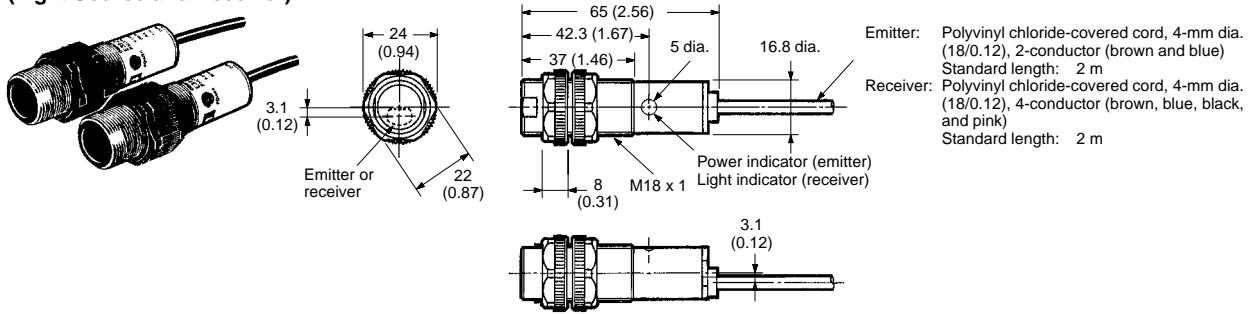

E3F2-R2C4, E3F2-R2B4 E3F2-DS10C4-N, E3F2-DS10B4-N

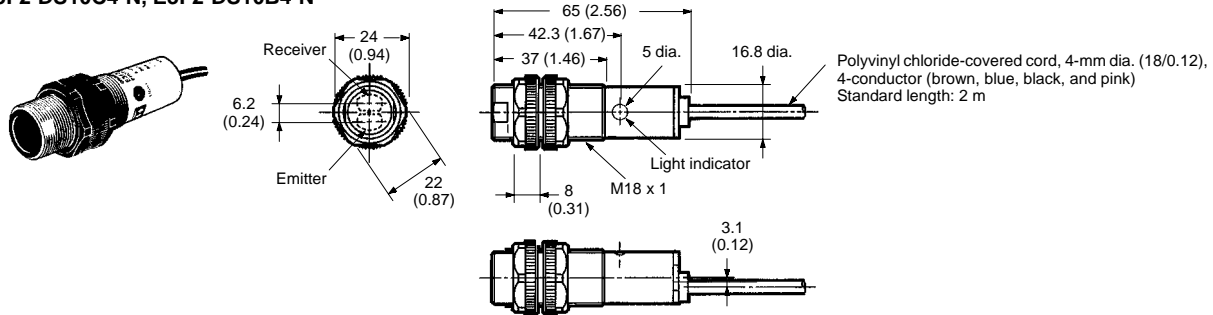

E3F2-DS30C4, E3F2-DS30B4

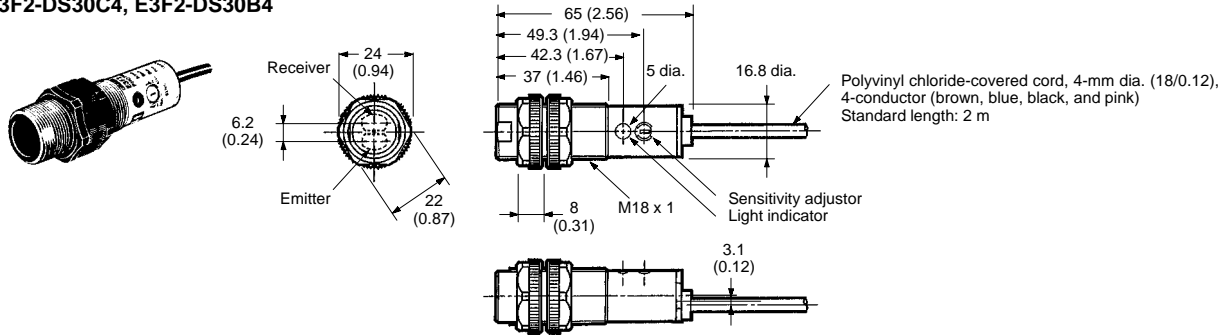

E3F2-3Z1, E3F2-3Z2 (Light Source and Receiver)

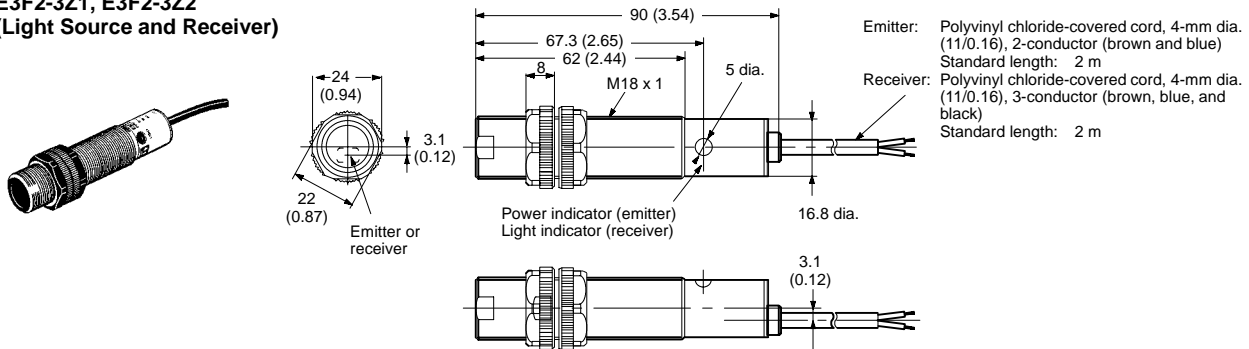

E3F2-R2□4-P1
E3F2-DS10□4-P1

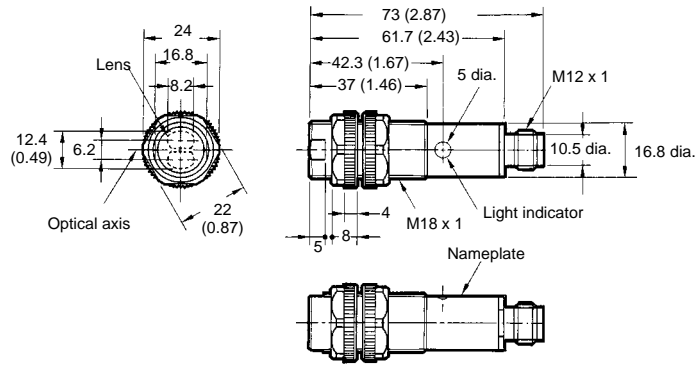

E3F2-DS30□4-P1

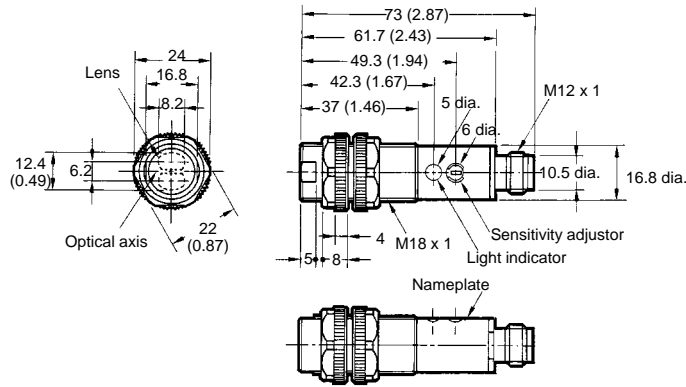

E3F2-3□□4-P1

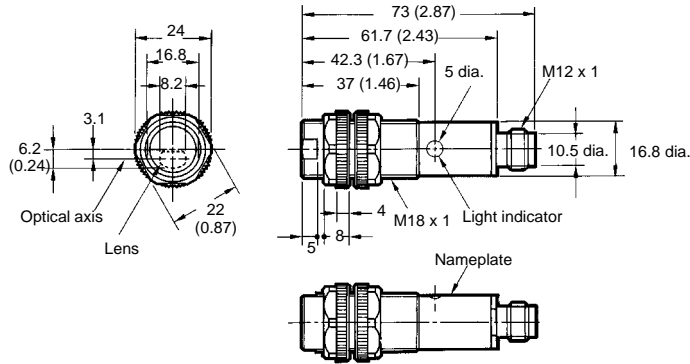

E3F2-R2Z1, E3F2-R2Z2
E3F2-DS10Z1-N,
E3F2-DS10Z2-N

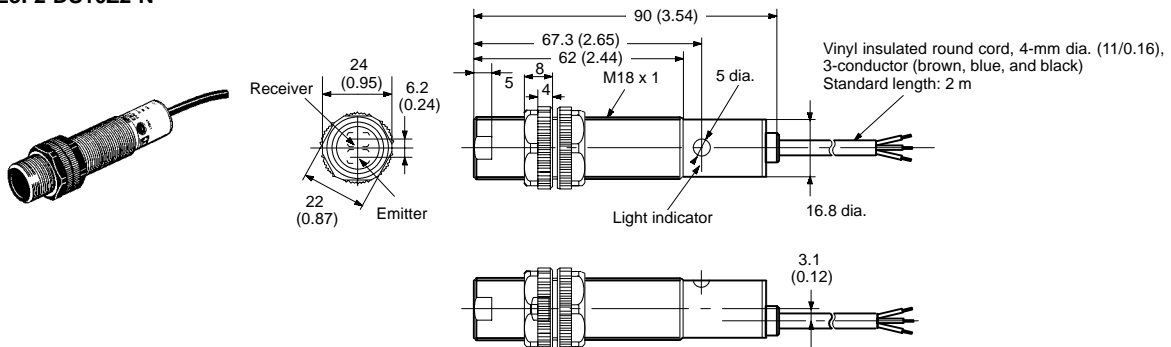

■ ACCESSORIES

E39-R1 Reflector

The reflector supplied with E3F-R1□□ retroreflective type sensors does not include a mounting bracket.

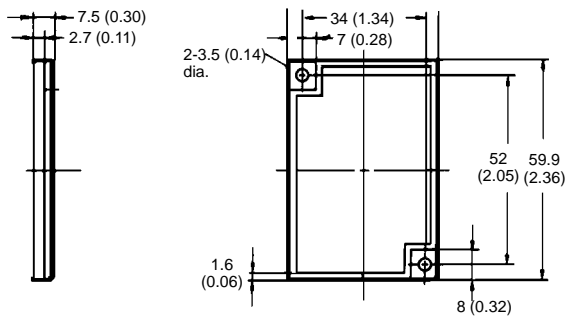

E39-L7 Reflector Adapter

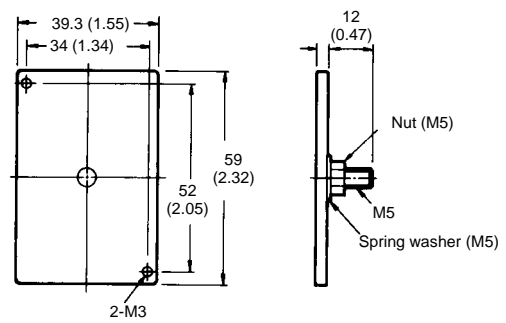

E39-R3 Reflector

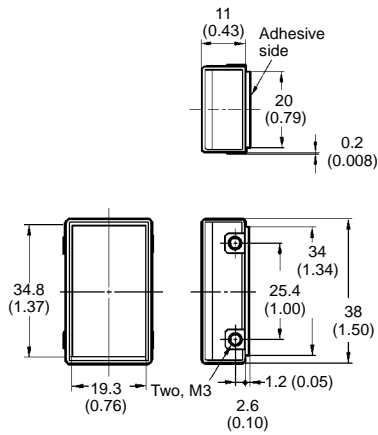

Mounting Bracket for E39-R3 (Sold Together)

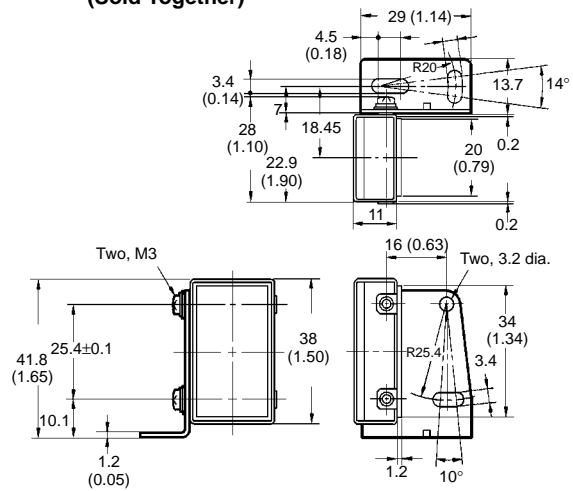

E39-RSA Reflector

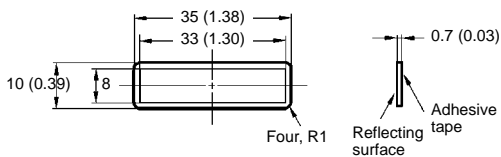

E39-RSB Reflector

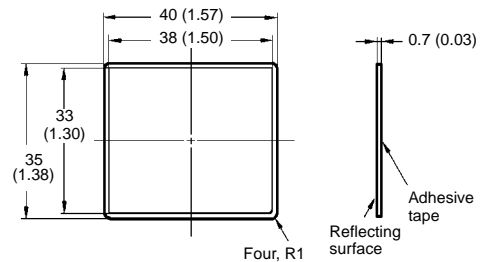

E39-RU1 Right Angle Adapter

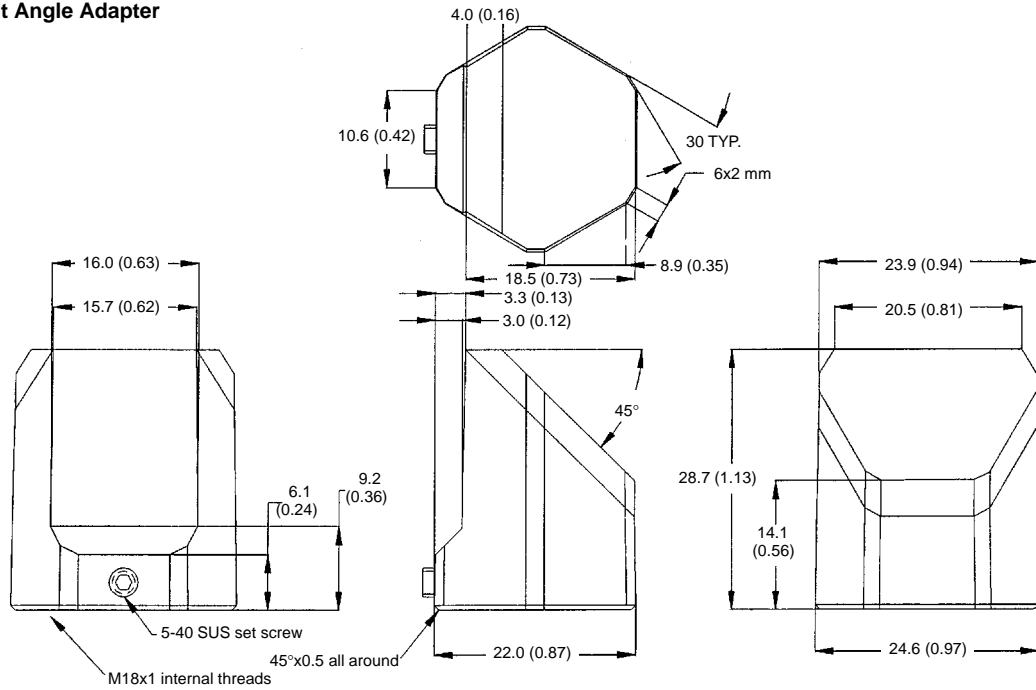

■ MOUNTING

Do not exceed a torque value of 20 kg-cm (2.0 N-m, 17.4 in-lbs) when tightening the adapter onto the sensor.

Use a 1/16" (1.5 mm) hex key on the set screw to secure the adapter to the E3F2. Do not exceed a torque of 3.5 kg-cm (0.35 N-m, 3.0 in-lbs). When set properly, the set screw will still extend beyond the adapter wall. Make sure to loosen the set screw before removing the adapter from the sensor.

Y92E-B18 Mounting Bracket

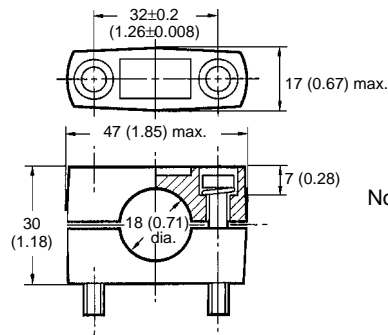
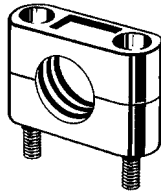

Note: Hexagonal nut: M5 x 32
Material: plastic

E39-F31 Lens Cap

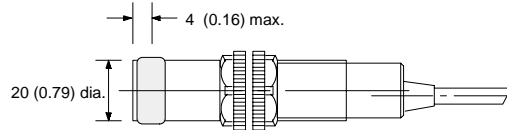
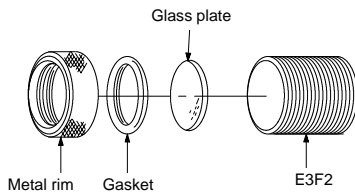

OPTIONAL CONNECTOR CORDSETS

Straight Connector Cordsets

Y96E-44SD□

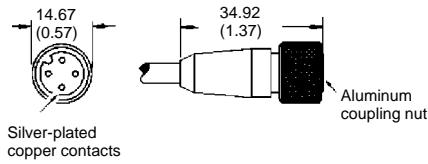

22 AWG, PVC jacketed cable rated for 300 V, 90°C:
 2 m (6.56 ft) length for Y96E-44SD2
 5 m (16.40 ft) length for Y96E-44SD5
 10 m (32.81 ft) length for Y96E-44SD10

Right Angle Connector Cordsets

Y96E-44RD□

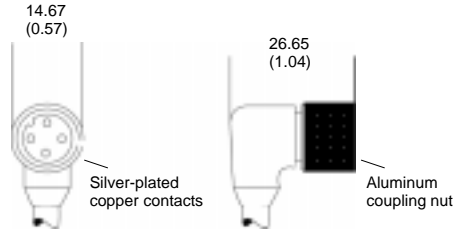

22 AWG, PVC jacketed cable rated for 300 V, 90°C:
 2 m (6.56 ft) length for Y96E-44RD2
 5 m (16.40 ft) length for Y96E-44RD5
 10 m (32.81 ft) length for Y96E-44RD10

Note: Cable may be extended to a maximum of 200 m (656 ft.)

Terminals/Connections

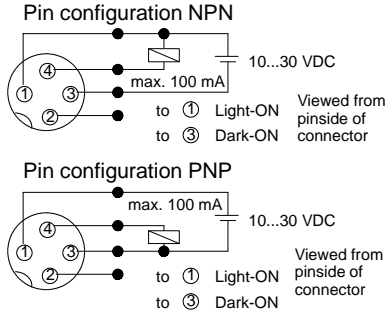

Assembly Directions

Insert the M12 threaded end of the sensor into socket of connector so that the notch correctly aligns the pins. Tighten the coupling nut by hand, not using a tool, until all the threads on the rear of the sensor are covered. This assures a positive connection, important for installations with vibration.

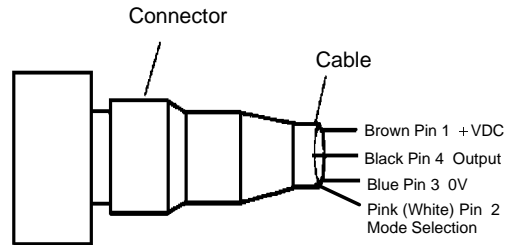

Note: Water tightness with connector is only valid when authorized connections are used. Cordset wire colors are shown in parentheses.

NOTE: DIMENSIONS SHOWN ARE IN MILLIMETERS. To convert millimeters to inches divide by 25.4.

OMRON®

Omron Europe B.V. EMA-ISD, tel:+31 23 5681390, fax:+31 23 5681397, <http://www.eu.omron.com/ema>