

PCB Version of the General Purpose Relay Series

- Good general purpose switching relay.
- Arc barrier standard on 3- and 4-pole relays.
- Withstand voltage: 2,000 VAC.
- UL and CSA approved.

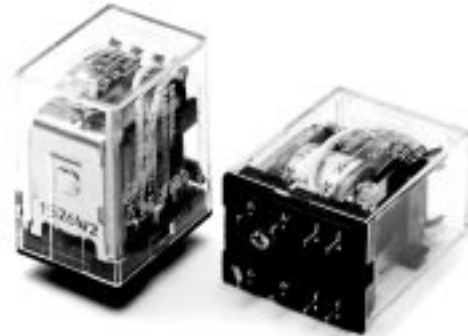

Ordering Information

Type		PCB terminals
Standard	DPDT	MY2-02
	DPDT (Bifurcated)	MY2Z-02
	3PDT	MY3-02
	4PDT	MY4-02
	4PDT (Bifurcated)	MY4Z-02

Note: When ordering, add the rated coil voltage to the model number. Rated coil voltages are given in the coil ratings table below.

Example: MY2, 12 VDC

Rated coil voltage

Specifications

■ Coil Ratings

Rated voltage	Rated current (mA)		Coil resistance (Ω)	Inductance (H reference value)		Must operate	Must release	Max. voltage	Power consumption (approx.)	
	50HZ	60Hz		Arm. OFF	Arm. ON					
AC	6V	214.1	183	12.2	0.04	0.08	80% max.	30% min.	110%	1.0 to 1.2 VA (60Hz)
	12V	106.5	90	46	0.17	0.33				
	24V	53.8	46	180	0.69	1.30				
	50V	25.7	22	788	3.22	5.66				
	100/110V	11.7 12.9	10/11	3,750	14.54	24.60				
	110/120V	9.9 10.8	8.4/9.2	4,430	19.20	32.10				
	200/220V	6.2 6.8	5.3/5.8	12,950	54.75	94.07				
	220/240V	4.8 5.3	4.2/4.6	18,790	83.50	136.40				
DC	6V	150		40	0.17	0.33	10% min.		0.9W	
	12V	75		160	0.73	1.37				
	24V	36.9		650	3.20	5.72				
	48V	18.5		2,600	10.60	21.00				
	100/110V	9.1 10.0		11,000	45.60	86.20				

Note: 1. The rated current and coil resistance are measured at a coil temperature of 23°C with tolerances of -15%/+20% for rated currents and ±15% for DC coil resistance.

2. Performance characteristic data is measured at a coil temperature of 23°C.

3. The must operate and must release voltages for High-sensitivity relays was measured at the rated power supply voltage.

4. AC coil resistance and impedance are provided as reference values (at 60Hz).

5. Power consumption drop was measured for the above data. When driving transistors, check leakage current and connect a bleeder resistor if required.

■ Contact Ratings

Item	Double or three pole		Four pole	
	Resistive load ($\cos\phi=1$)	Inductive load ($\cos\phi=0.4$, L/R=7ms)	Resistive load ($\cos\phi=1$)	Inductive load ($\cos\phi=0.4$, L/R=7ms)
Rated load	5A, 220 VAC 5A, 24 VDC	2A, 220 VAC 2A, 24 VDC	3A, 220 VAC 3A, 24 VDC	0.8A, 220 VAC 1.5A, 24 VDC
Carry current	5A		3A	
Max. switching voltage	250 VAC 125 VDC			
Max. switching current	5A		3A	
Max. switching capacity	1,100 VA 120W	440 VA 48W	660 VA 72W	16 VA 36W
Min. permissible load*	Standard type: 100mA, 5VDC Bifurcated type: 100 μ A, 1VDC		Standard and High sensitivity types: 1mA, 1VDC Bifurcated type: 100 μ A, 1VDC	

*Note: P level: $\lambda_{60} = 0.1 \times 10^{-6}$ /operation

■ Characteristics

Contact resistance	50 m Ω max.
Operate (set) time	20 ms max.
Release (reset) time	20 ms max.
Max. operating frequency	Mechanical: 18,000 operations/hr Electrical: 1,800 operations/hr (under rated load)
Insulation resistance	1,000 M Ω min. (at 500 VDC)
Dielectric withstand voltage	2,000 VAC, 50/60 Hz for 1 min (1,000 VAC between contacts of same polarity)
Vibration resistance	Destruction: 10 to 55 Hz, 1.0-mm double amplitude Malfunction: 10 to 55 Hz, 1.0-mm double amplitude
Shock resistance	Destruction: 1,000 m/s ² (approx. 100G) Malfunction: 200 m/s ² (approx. 20G)
Life expectancy	See next table
Ambient temperature	DPDT & DPDT Bifurcated: Operating: -55°C to 70°C (with no icing) All others: Operating: -55°C to 60°C (with no icing)
Ambient humidity	Operating: 35% to 85%
Weight	Approx. 85 g

Note: The data shown is an initial value.

■ Life Expectancy Characteristics

Relays	Mechanical Life (at 18,000 operations/hr)	Electrical Life (at 1,800 operations/hr under rated load)
Normal	AC: 50,000,000 operations min. DC: 100,000,000 operations min.	2-, 3-pole: 500,000 operations min. 4-pole: 200,000 operations min.
With bifurcated contacts	2-pole: 50,000,000 operations min. 4-pole: 20,000,000 operations min.	2-pole: 200,000 operations min. 4-pole: 100,000 operations min.

■ Life Expectancy under Real Loads

MY2

Rated voltage	Load type	Conditions	Operating frequency	Electrical life
Normal	AC motor	50W, 100 VAC single phase with 2.8A inrush current, 0.4A carry current	ON for 2 seconds, OFF for 30 seconds	100,000 operations
		50W, 100 VAC single phase with 1.6A inrush current, 1A carry current	ON for 1 second, OFF for 30 seconds	300,000 operations
With bifurcated contacts	AC solenoid	24W with 1A carry current	ON for 1.5 seconds, OFF for 1.5 seconds	4,000,000 operations

MY4

Rated voltage	Load type	Conditions	Operating frequency	Electrical life
100 VAC	AC solenoid	50 VA with 2A inrush current, 0.7A carry current	ON for 1 second OFF for 3 seconds	25,000 operations
	DC magnetic switch	25 W with L/R=40ms, 0.2A carry current		
	AC magnetic switch	35 VA with 1.5A inrush current, 0.35A carry current		500,000 operations

Rated voltage	Load type	Conditions	Operating frequency	Electrical life
24 VDC	DC solenoid	40W with L/R=10ms, 1.6A carry current	ON for 5 seconds OFF for 1.5 seconds	5,000,000 operations
		30W with L/R=10ms, 0.34A carry current		6,000,000 operations

Approved by Standards

Some MY relays are available in models meeting various safety standards. When ordering, you must specify the desired standards. Refer to Ordering Information for specific models. Note that the rating recognised by the various standards sometimes vary from the ratings of the individual relays.

UL 508 Recognitions (File No. 41515)

No. of poles	Coil ratings	Contact ratings
2	6 to 240 VAC 6 to 120 VDC	5A, 120 VAC resistive load 5A, 28 VDC resistive load 5A, 240 VAC inductive load
3		5A, 28 VDC resistive load 5A, 240 VAC inductive load
4	6 to 240 VAC 6 to 120 VDC	3A, 28 VDC resistive load 3A, 120 VAC inductive load 1.5A, 240 VAC inductive load 5A, 240 VAC inductive load (between contacts of same polarity) 5A, 28 VDC resistive load (between contacts of same polarity) 0.2A, 120 VDC

CSA 22.2 No. 0 and No. 14 (File No. LR31928)

Model	No. of poles	Coil ratings	Contact ratings
MY□	2, 3	6 to 240 VAC	5A, 28 VDC resistive load 5A, 240 VAC inductive load
	4	6 to 120 VDC	3A, 28 VDC resistive load 3A, 240 VAC inductive load 5A, 240 VAC inductive load (between contacts of same polarity) 5A, 28 VDC resistive load (between contacts of same polarity) 0.2A, 120 VDC

SEV

Model	No. of poles	Coil ratings	Contact ratings
MY□	2, 3	6 to 100 VDC 6 to 220 VAC	5A, 200 VAC 5A, 24 VAC

Engineering Data

Max. Switching Capacity

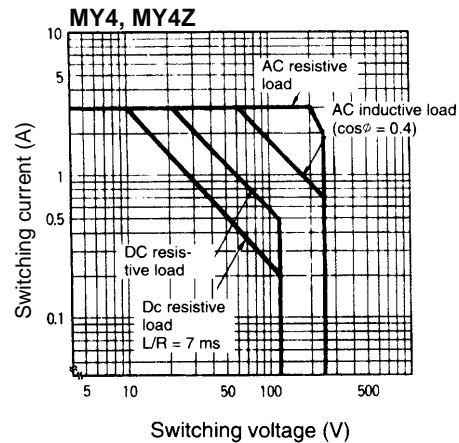
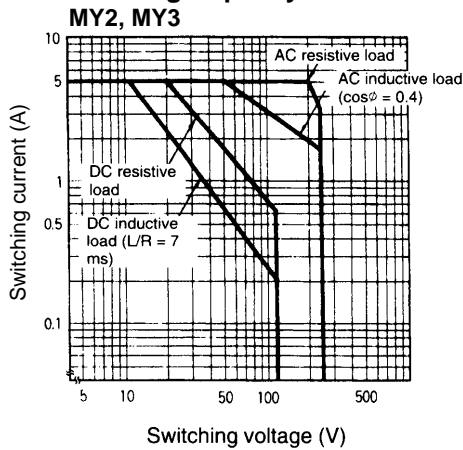

Life Expectancy

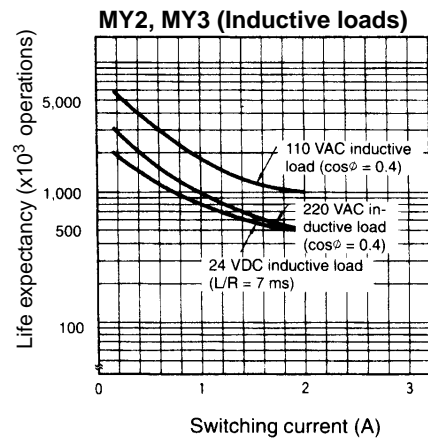
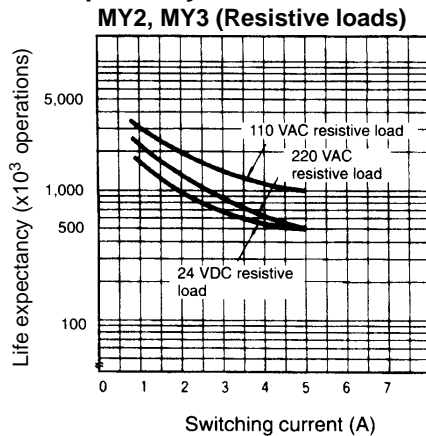

MY4 (Resistive loads)

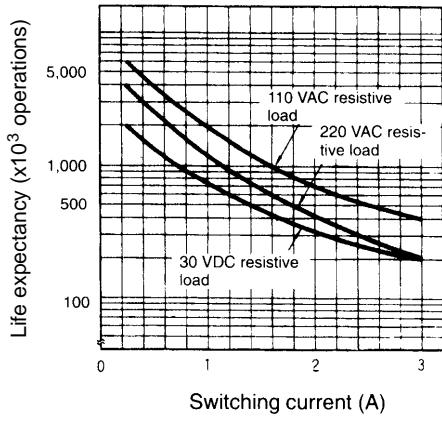

MY4 (Inductive loads)

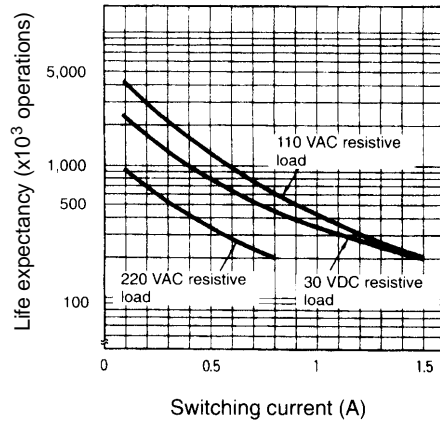

MY4Z (Resistive loads)

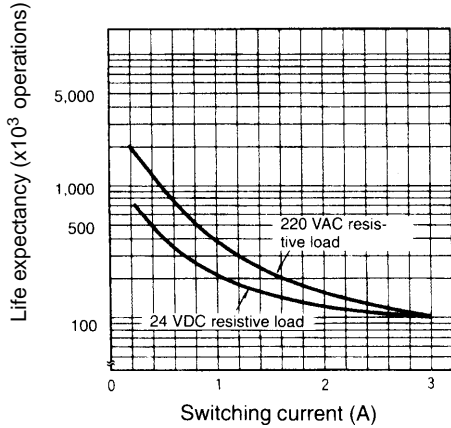

MY4Z (Inductive loads)

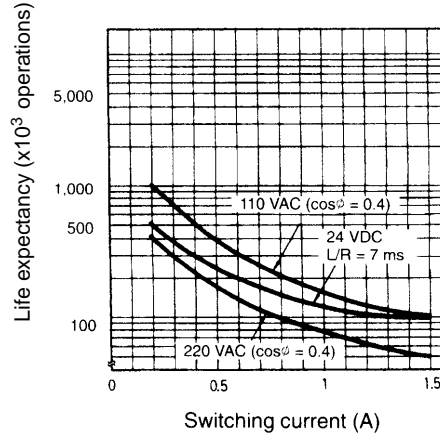

Dimensions

- Note:**
1. The figures in parentheses are for MY4-02.
 2. The above dimensions also apply to the DPDT and 3PDT relays.
 3. The internal connections of the above relays are same as those of MY□ relays.

MY□-02

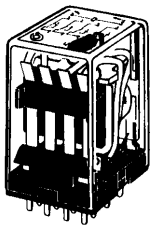

MY4-02 (4PDT)

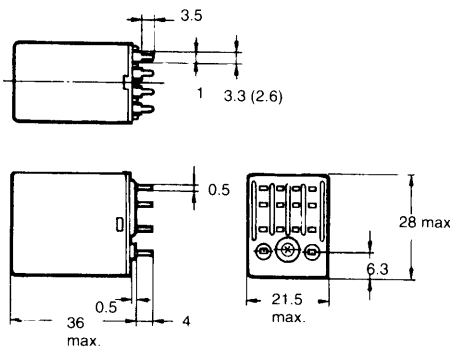

PC Board mounting holes

